



Skudo®

Temporary Surface Protection



Innovative, Purpose-Built Surface Protection Systems.

Save the headache, time and money of making repairs.

“By far, Skudo® is the most durable floor protection system on the market.”

- Doug Carlton,
Concrete Décor Magazine



Heavy Traffic



Medium Traffic



Light Traffic

The most durable temporary surface protection available against:

- Machinery use
- Foot traffic
- Spills – including mortar, stucco, paint, oil
- Stains – including rust, chalk, hydraulic fluid
- Dirt, dust and debris
- Scaffolding and shoring
- Water
- Mold
- UV exposure
- Sparks and fire

“Skudo held up well! We had a couple of hydraulic leaks from one of the electric man lifts, resulting in a puddle of oil on the floor overnight. Skudo did not allow the oil to penetrate through.”

- Project Manager
Neeser Construction



This Is All We Do.

Skudo has a protection solution for almost all surface types and work environments: most substrates, vertical or horizontal, indoors or outdoors, residential or commercial.

- Concrete
- Tile
- Hardwood
- Terrazzo
- Epoxy
- Stone & Marble
- Cabinets
- Countertops
- Stairs
- Bathtubs & Showers
- Columns & Pillars
- TPO Roofs
- Windows
- Metal Railings



Temporarily
protects the
entire surface
area.

Leaves the
surface clean
and
undamaged

Improves job site safety



- Non-slip work surface in both wet and dry conditions.
- Eliminates slip and trip hazards
- Stationary – stays in place despite worker activity and weather
- High visibility colors



CONCRETE

Project Examples

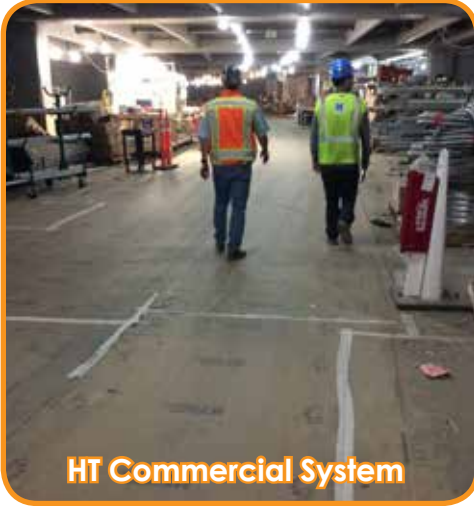

HT Commercial System



SkudoBoard



MT Commercial System



SkudoBoard Column Guard



SkudoBoard



All Terrain Mat



MT Commercial System



HT Commercial System



SkudoBoard

Innovative, purpose-built surface protection systems. This is all we do.

www.skudousa.com 1-888-SKUDO-11 (1-888-758-3611)



GLASS & METAL

Project Examples



Innovative, purpose-built surface protection systems. This is all we do.

www.skudousa.com 1-888-SKUDO-11 (1-888-758-3611)



HARDWOOD/GYM

Project Examples



MT Commercial System



SkudoBoard



SkudoBoard +
LT Tack-Mat



HT Commercial System



MT Commercial System



HT Tack-Mat



LT Tack-Mat



SkudoBoard



HI Tack-Mat

Innovative, purpose-built surface protection systems. This is all we do.

www.skudousa.com 1-888-SKUDO-11 (1-888-758-3611)



KITCHEN & BATH

Project Examples

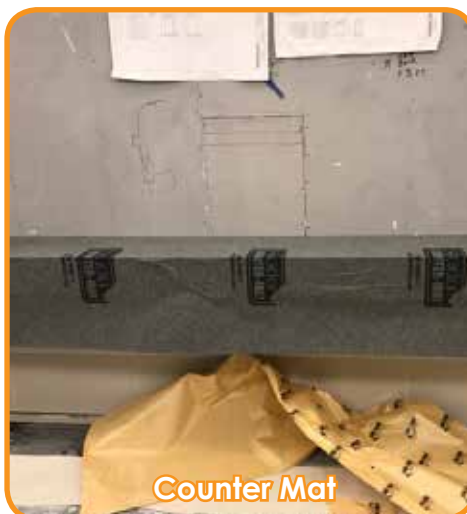

Innovative, purpose-built surface protection systems. This is all we do.

www.skudousa.com 1-888-SKUDO-11 (1-888-758-3611)



STAIRS

Project Examples



HT Tack-Mat



HT Commercial System



SkudoBoard HT



HT Tack-Mat



All-Terrain Mat



LT Tack-Mat

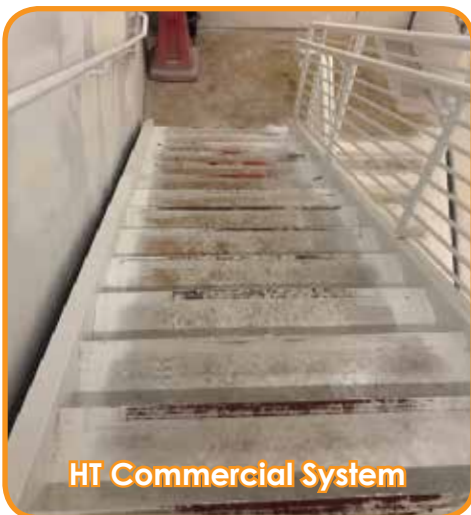

HT Commercial System



MT Commercial System



HT Tack-Mat

Innovative, purpose-built surface protection systems. This is all we do.

www.skudousa.com 1-888-SKUDO-11 (1-888-758-3611)



TERRAZZO

Project Examples



MT Commercial System



HT Commercial System



HI Tack-Mat



HT Tack-Mat



MT Commercial System



SkudoBoard Interlock



**SkudoBoard +
HT Tack Mat**



Counter Mat



MT Commercial System

Innovative, purpose-built surface protection systems. This is all we do.

www.skudousa.com 1-888-SKUDO-11 (1-888-758-3611)



TILE & STONE

Project Examples



LT Tack-Mat



HI Tack-Mat



Counter Mat



**SkudoBoard+
LT Tack-Mat**



HT Tack-Mat



SkudoBoard



HT Tack-Mat



LT Tack-Mat



HT Tack-Mat & HI Tack-Mat

Innovative, purpose-built surface protection systems. This is all we do.

www.skudousa.com 1-888-SKUDO-11 (1-888-758-3611)

{ Tab Here ----->
“COMMERCIAL SYSTEM” }



Description

Skudo HT (Heavy Traffic) Commercial System is a fully adhered, breathable, temporary surface protection system for commercial projects. It consists of a flexible, peelable Concrete Base Coat and Skudo HT (Heavy Traffic) Mat. The HT Commercial System is our most durable protection, withstanding machinery, shoring and tough environments. It is perfectly suited for protecting concrete, allowing full cure without creating hydration (cure) lines.

Like all Skudo products, the HT Mat temporarily bonds to the surface, blocking debris, materials and spills from damaging the protected surface. Skudo HT provides a slip resistant, seamless and stationary work surface, ideal for placing construction marks and layouts.

Skudo HT is designed to protect surfaces from commercial traffic during construction for up to 12 months. Once the project is completed, the HT Mat is peeled up, revealing a clean and damage-free surface.

Uses

- Protects most surfaces, including freshly placed concrete as early as 14 days.
 - *Note: This is subject to slab thickness, mix design, weather, etc. Please contact your Skudo Rep to determine suitability
- Protects polished concrete and terrazzo
- Areas can be polished and protected before interior walls are erected. Framing can be placed over the top of the Commercial System, which then can be left in place underneath
- Under Scaffolding & Shoring
- Flooring and Staircases
- Works as a blank canvas for all types of construction marks and layouts - won't stain or damage surface

Benefits

- Reliable surface protection for Heavy construction site traffic
- Breathable system
- Superior spill, stain and water resistance (proven against flooding)
- Resistance to UV, rust, impact, and welding splatter
- Class 1 Fire/Flame retardant according to ASTM E 648 and NFPA 253 standards.
- Antibacterial/Antifungal: Test-verified protection against bacteria and molds that cause infection. (ISO-20743)
- Safer working surface
- High slip resistance in wet and dry conditions
- Seamless and stationary
- Cleans surface upon peel up removal



Protected in the United States by patent #10190004
Canada patent #2850385

Innovative, purpose-built surface protection systems. This is all we do.

www.skudousa.com 1-888-SKUDO-11 (1-888-758-3611)

V 3.8 4.16.20



Substrate Suitability

Raw Concrete (Smooth)	Very Good	Tiles - Porcelain	Excellent
Polished Concrete (Sealed)	Excellent	Marble / Stone - Smooth	Excellent
Decorative Concrete	Excellent	Marble / Stone - Coarse	Very Good
Brushed Concrete	Good	Epoxy Coated Surfaces	Excellent
Aged Concrete	Excellent	Primed Steel	Excellent
Acid Washed Concrete	Poor	Fiberglass	Excellent
Stairs	Good	Laminate	Good
Terrazzo	Excellent	High Pressure Laminate	Good
Hardwood (Sealed)	Good	Topping/Overlays	Avoid
Tiles - Ceramic	Excellent		

Product Coverage

HT Mat	800 sq. ft./roll 6.5'W x 123'L
Base Coat	
Smooth/Troweled Surfaces	150 sq. ft./gal
Textured/Medium Broomed finish	as low as 80 sq. ft./gal

The surfaces listed above provide a guide only and vary due to a range of factors. For substrates not listed above, please refer to your Skudo representative. All substrates should be tested for suitability by doing a small spot test. No warranties implied or otherwise are given for the usage of this product.

Application

The Skudo Commercial System is applied in two steps:

1. The water based Concrete Base Coat is applied using our Notched Squeegee Method. See application sheet for details.
2. The HT Mat is rolled out and pressed into wet Base Coat. For more information on detailed application, please refer to our Website, Product Application Sheet or Label.

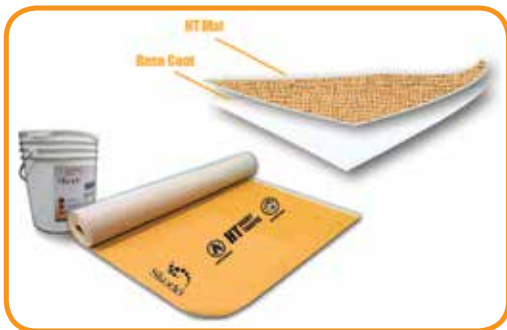

NOTE: For a detailed explanation of Skudo Commercial Mat System usage, application process and limitations, please see our website which includes step-by-step instructions

Precautions

- Do not dilute.
- Should not be applied to concrete exposed to excessive moisture. Skudo must be kept dry for 24 hours after installation.
- Do not apply if the temperature of the concrete or air temperature is below 40° F (4° C).
- If installing over sealed, guarded or protected concrete or terrazzo, it is critical sealer is fully cured. Dry to the touch is not sufficient. Always consult a Skudo Representative for compatibility.
- If the Commercial System is exposed to excessive standing water, extremely heavy rainfall or drainerunoff, water can soften the mat, breaking the bond between the protected substrate and Skudo Base Coat. If this occurs, normal lift traffic may damage the Mat. Drain or squeegee water off the affected area and attempt to keep traffic off the mat until it has dried. Once dried, the mat will return to its original strength and in most cases will re-adhere to the substrate.
- After Installation, remove any visible Base Coat after allowing it to completely dry, then peel up. Any attempts to wipe up or press in the exposed wet Base Coat will negate its film forming properties making removal extremely difficult. UV exposure degrades the peelability of the Base Coat.



Innovative, purpose-built surface protection systems. This is all we do.

www.skudousa.com 1-888-SKUDO-11 (1-888-758-3611)

V 3.8 4.16.20



Heavy Traffic (HT) Commercial System Project Examples



Stairs

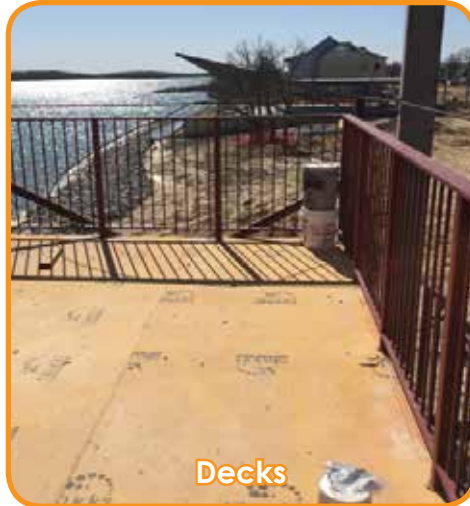

Decks



Sidewalks

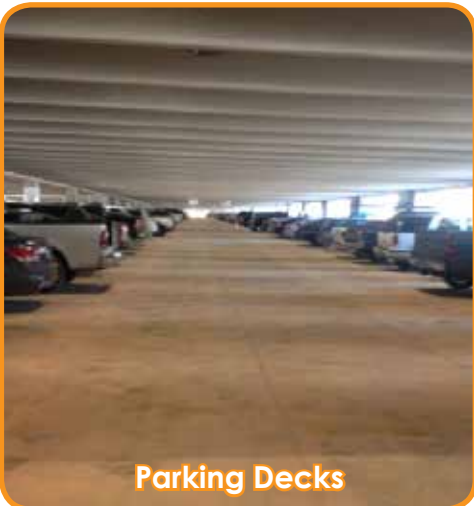

Parking Decks

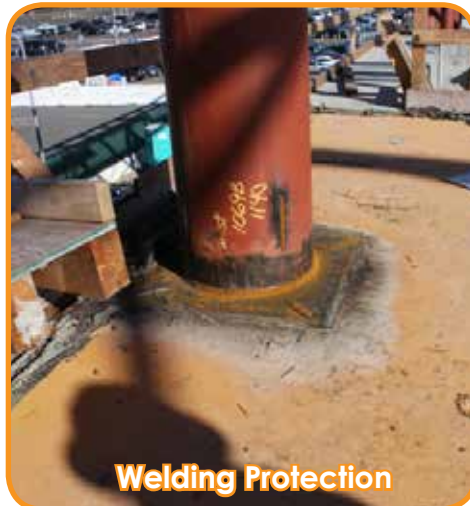

Welding Protection

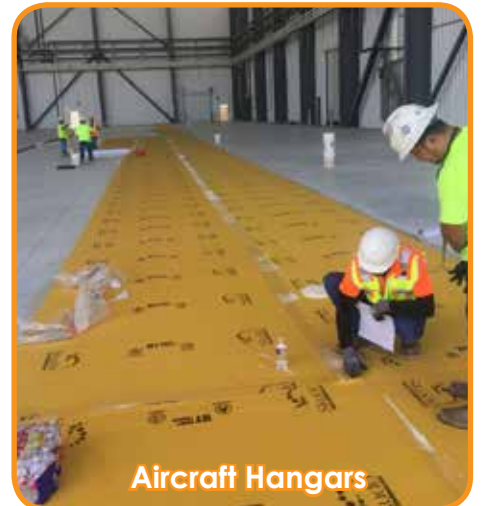

Aircraft Hangars



Under Heavy Machinery



Under Equipment and Debris



Under Framing

Innovative, purpose-built surface protection systems. This is all we do.

www.skudousa.com 1-888-SKUDO-11 (1-888-758-3611)



Construction Marks/Layouts - Project Examples

Skudo HT Commercial System



Adheres and remains stationary • Use for all types of construction layouts • Fire Retardant
No need to worry about staining • Won't rub off or wash away • Antibacterial/Antimicrobial



Use for: Wall Layouts, Anchor Points, HVAC Lines, Sprinkler Lines, Plumbing Lines, Door & Window Jambes, Wrapped Openings, Electric Trays, Ceiling Grids, Overhead Units, and more!

Innovative, purpose-built surface protection systems. This is all we do.

www.skudousa.com 1-888-SKUDO-11 (1-888-758-3611)



Description

The Skudo MT (Medium Traffic) Commercial System provides temporary surface protection on interior commercial construction jobs. It is comprised of a flexible, peelable Concrete Base Coat and the MT (Medium Traffic) Mat, which together create a homogeneous covering that does not permit contaminants or debris to get between it and the substrate it's protecting.

The MT Commercial System protects against mold, impact and light machinery. With the highest level of slip resistance of all the Skudo products, the MT Mat also provides a safe working environment with a non-slip, seamless and stationary work surface. MT Commercial can protect surfaces up to 9 months.

(NOTE: Interior use only)

Once the project is completed, the MT Mat is simply peeled up and disposed of in general site garbage bins.

Uses

- Protects most surfaces, including freshly placed concrete as early as 21 days.
 - *Note: This is subject to slab thickness, mix design, weather, etc. Please contact your Skudo Rep to determine suitability
- Protects polished concrete and terrazzo
- Under Scaffolding & Shoring, Light Machinery

Benefits

- ✓ Reliable surface protection for Medium construction site traffic
 - Spill, stain and water resistance
 - Resistance to impact
 - Antibacterial/Antifungal: Test-verified protection against bacteria and molds that cause infection. (ISO-20743)
- ✓ Safer working surface
 - High slip resistance in wet and dry conditions
 - Seamless and stationary
- ✓ Cleans surface upon peel up removal



Protected in the United States by patent #10190004
Canada patent #2850385

Innovative, purpose-built surface protection systems. This is all we do.

www.skudousa.com 1-888-SKUDO-11 (1-888-758-3611)

V 3.6 3.4.20



Substrate Suitability

Raw Concrete (Smooth)	Very Good	Tiles - Porcelain	Excellent
Polished Concrete (Sealed)	Excellent	Marble / Stone - Smooth	Excellent
Decorative Concrete	Good	Marble / Stone - Coarse	Very Good
Brushed Concrete	Fair	Epoxy Coated Surfaces	Very Good
Aged Concrete	Good	Primed Steel	Excellent
Acid Washed Concrete	Poor	Fiberglass	Excellent
Stairs	Very Good	Laminate	Good
Terrazzo	Excellent	High Pressure Laminate	Good
Hardwood (Sealed)	Good	Topping/Overlays	Avoid
Tiles - Ceramic	Excellent		

Product Coverage

MT Mat	800 sq. ft./roll 6.5'W x 123'L
Base Coat	
Smooth/Troweled Surfaces	150 sq. ft./gal
Textured/Medium Broomed finish	as low as 80 sq. ft./gal

The surfaces listed above provide a guide only and vary due to a range of factors. For substrates not listed above, please refer to your Skudo representative. All substrates should be tested for suitability by doing a small spot test. No warranties implied or otherwise are given for the usage of this product.

Application

The Skudo Commercial System is applied in two steps:

1. The water based Concrete Base Coat is applied using our Notched Squeegee Method. See application sheet for details.
2. The MT Mat is rolled out and pressed into wet Base Coat. For more information on detailed application, please refer to our Website, Product Application Sheet or Label.

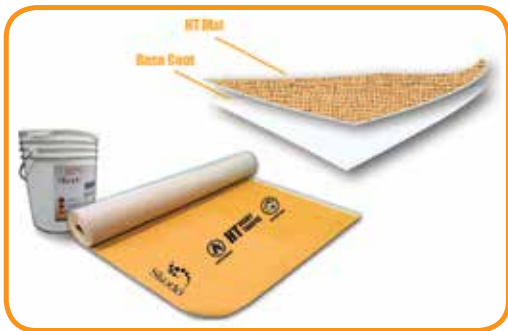

NOTE: For a detailed explanation of Skudo Commercial Mat System usage, application process and limitations, please see our website which includes step-by-step instructions

Precautions

- Do not dilute.
- Should not be applied to concrete exposed to excessive moisture. Skudo must be kept dry for 24 hours after installation.
- Do not apply if the temperature of the concrete or air temperature is below 40° F (4° C).
- If installing over sealed, guarded or protected concrete or terrazzo, it is critical sealer is fully cured. Dry to the touch is not sufficient. Always consult a Skudo Representative for compatibility.
- If the Commercial System is exposed to excessive standing water, extremely heavy rainfall or drainer runoff, water can soften the mat, breaking the bond between the protected substrate and Skudo Base Coat. If this occurs, normal lift traffic may damage the Mat. Drain or squeegee water off the affected area and attempt to keep traffic off the mat until it has dried. Once dried, the mat will return to its original strength and in most cases will re-adhere to the substrate.
- After Installation, remove any visible Base Coat after allowing it to completely dry, then peel up. Any attempts to wipe up or press in the exposed wet Base Coat will negate its film forming properties making removal extremely difficult. UV exposure degrades the peelability of the Base Coat.



Innovative, purpose-built surface protection systems. This is all we do.

www.skudousa.com 1-888-SKUDO-11 (1-888-758-3611)

V 3.6 3.4.20



Medium Traffic (MT) Commercial System Project Examples



Staging Areas



Residential

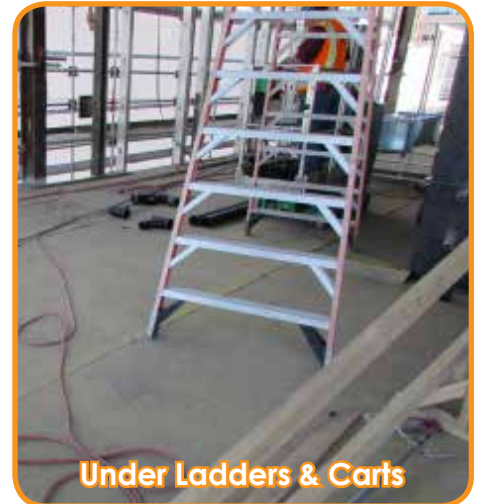

Under Ladders & Carts



Gymnasiums

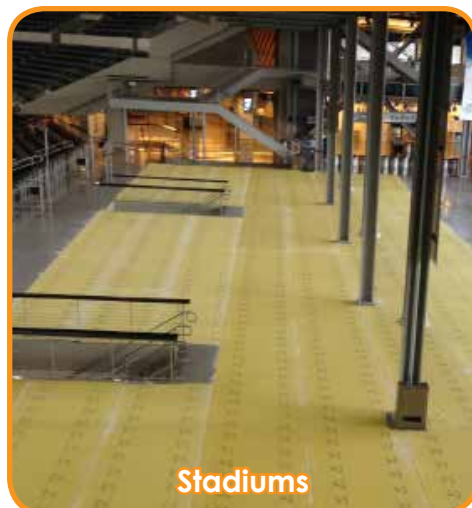

Stadiums



Under Light Machinery



Commercial Interiors



Under Materials and Debris



Mud/Moisture Protection

NOTE: MT Commercial System is intended for INTERIOR USE ONLY.

Innovative, purpose-built surface protection systems. This is all we do.

www.skudousa.com 1-888-SKUDO-11 (1-888-758-3611)



Application Preparation & Summary

PREPARATION

IMPORTANT: Before applying the Skudo Mat System:

- Ensure Skudo is suitable for the substrate on which it will be applied
NOTE: avoid applying Skudo to unsealed hardwood, carpet, rubber, painted surfaces, weak or latex based grout, unfilled travertine, pavers, high pH substrates (above 11.0), linoleums and vinyls that are effected by high pH of Base Coat (See www.SkudoUSA.com for complete details)
- Ensure the surface pH is below 11.0 and relative humidity (RH) is 90% or lower.
- Ensure the surface temperature is above 40 and below 105 degrees F.
- Do not apply the system externally if rain is likely within 24 hours.
- If applied, ensure all densifiers, grouts, sealers, guards, epoxies, etc. have been cured / burnished to their manufacturer specifications (touch dry is not sufficient). In some instances, it is beneficial to wait to apply any topical coatings (sealers, etc.) until after Skudo has been removed. Consult Skudo representative if uncertain.
- Ensure the area is clean and free from any foreign materials that will contaminate or compromise the Base Coat.

Always spot test Skudo to specific job site conditions



Thoroughly sweep the surface to ensure the area is clean and free of debris/foreign materials that will compromise and contaminate the Base Coat.

JOB ASSESSMENT CONSIDERATIONS

Know which grade of Skudo you are applying (Orange-HT or Yellow-MT), and adhere to the limitations listed in the Product Data, including:

- 1. Expected Construction Traffic**
 - Machinery - HT can handle moderate machinery, MT can handle infrequent and light machinery.
 - Shoring & Scaffolding – Both HT and MT Mat can handle.

2. Job duration and location

If the job is exterior, you should be using HT only. The average on site life of Skudo Mats is as follows:

- HT Mat – Up to 12 months
- MT Mat – Up to 9 months

3. Water and spill resistance:

- HT offers the highest water and spill resistance. MT offers moderate resistance.

SPREAD RATES

It is critical that the Skudo Base Coat be applied consistently to a thickness of at least 10 mils wet.

The spread rates of the Base Coat will vary due to weather and how porous the substrate is on which it will be applied.

- On flat sealed continuous substrates the Base Coat will yield approximately 150 sq. ft. per gallon.
- On raw concrete or substrates with a lot of undulation or grout lines the yield can significantly drop below the rate above.

BASE COAT APPLICATION METHODS & TOOLS



NOTCHED SQUEEGEE & BACK ROLL

Tools
(1) Skudo Commercial Mat Squeegee Installation Pack

Application Rate
10,000-12,000 SF/ Day

Preparation
Thoroughly soak Back roller cover in Base Coat
Sweep debris off area

Clean up
Throw away roller covers when done
Overnight - submerge roller in Base Coat

Crew Needed
3 Man Crew

ONCE APPLIED

Once applied, clear the area of any traffic and cordon off the area for at least 3 hours to allow Skudo to fully dry (HT will take longer to dry, but it will be able to take foot traffic after 3 hours and machines the next day). Dry time may vary due to substrate temperature and porosity of the surface.

Tools and equipment should be washed out using warm soapy water.

Although the Skudo Base Coat is classed as Non Hazardous, avoid wash out entering drains, waterways and finished surfaces. Please refer to the SDS for more information.

PATCHING & MAINTENANCE

Should the Skudo Mats require patching, lift up the tear, apply fresh Base Coat underneath and press the Mat back down. Alternatively, you may apply a new section of the Skudo Mat with Base Coat over the hole.

REMOVAL



When ready to remove the Skudo Mat, work with a partner and simply lift a corner and peel it back at a 45 degree angle. To make the process easier and faster, nip the edge at 2 to 3 foot widths and tear it into thinner strips. Dispose of the Mat in general site garbage bins.

NOTE: Removal of the Mat when the temperature is below 36°F makes the System less peelable.

The time it takes to remove the Skudo Mat will depend upon factors such as the texture of the surface it was applied to, and whether or not there were any contaminants on the surface at the time of application.

RECOMMENDED: Use the Skudo Mat Puller to give more leverage and make the removal process easier on your hands.



Protected in the United States by patent #10190004

Innovative, purpose-built surface protection systems. This is all we do.

www.skudousa.com 1-888-SKUDO-11 (1-888-758-3611)



Application Guide



Step 1

Start with the Skudo Mat in a corner of the area to be covered.

Roll the Mat out 3 to 4 feet and align with a wall or edge of slab to ensure a straight roll out.

Lift the rolled out section over the rolled up portion of the Mat.



Step 2

After soaking the Back Roller in Base Coat, begin applying the Base Coat directly onto the surface using the Notched Squeegee and Back Roller. Make sure the Base Coat is applied in a consistent coat with a thickness of **10 Mils wet**.

Apply it to the surface across the **entire width** of the Skudo Mat roll.

Note : Rough or textured surfaces will require a thicker application of Base Coat.



Step 3

Lay the rolled out section of Skudo Mat back onto the wet Base Coat and press it in immediately, using either the Skudo Roller or a dry paint roller.

It is critical that the Skudo Mat is uniformly pressed into the Base Coat.

This now becomes the anchor for the rest of the roll.



Step 4

Continue to apply the Base Coat again in front of the roll.

When using the Skudo Notched Squeegee, ensure to pull the product away from the roll before back rolling.

Press in the Skudo Mat as you go, repeat process until the end of the row, taking note to ensure Base Coat thickness is **10 Mils wet**. Once applied, do not lift the Mat.



Step 5

Start the next row with the Skudo Mat as per Step 1, overlapping the edge up to the guide line. Roll out 4 to 5 feet of the Mat for alignment.

This will ensure that the next section will be straight and will not drift off this line further down the area of application.



Note:

The Base Coat can be used to adhere the overlap.

This makes the system more water tight which is important for projects that have not been dried in yet.

IMPORTANT: The Base Coat will dry clear (not white). Failure to apply correct thickness or properly 'Press' in the Mat may result in a poor lamination and possible failure on peel.



Scan to see step-by-step application instructions on our website, including our application video!

Innovative, purpose-built surface protection systems. This is all we do.

www.skudousa.com 1-888-SKUDO-11 (1-888-758-3611)

{ Tab Here ----->
“TACK-MAT” }



Description

Skudo's Heavy Traffic (HT) Construction Tack-Mat offers outstanding temporary surface protection for horizontal indoor surfaces including floors and stairs. HT Tack-Mat features a unique self-stick surface - simply peel the backing paper and apply.

HT Tack-Mat provides interior surface protection for commercial and residential projects for up to 12 months.

Benefits

- Strong bond with the surface blocks any dirt and debris from staining or damaging the protected substrate
- Provides protection from machinery, carts and foot traffic
- Protects from small spills of many chemicals, solvents, paints, and oils.
- Slip resistant surface that is seamless and stationary
- Protects against color changing UV rays
- Can be used in any temperature : -20°F to +200°F
- Proven Fire/Flame retardant according to Class 1 ASTM E 648 and NFPA 253 standards.
- Antibacterial/Antifungal: Test-verified protection against bacteria and molds that cause infection. (ISO-20743)
- Easy to adjust or inspect surface, simply peel up and re-position

Uses

Protects all surfaces during construction/remodeling including:

- Marble, Granite, and Stone *
- Hardwood* and laminate
- Ceramic and Porcelain Tile
- Glass, Epoxies, and Metals
- Sheet Vinyl
- Showers, bathtubs, and countertops

*Please see "Limitations" section (pg 2)



Slip Resistant Surface



Perfect for stairs



Commercial Bath



Durable

Innovative, purpose-built surface protection systems. This is all we do.

www.skudousa.com 1-888-SKUDO-11 (1-888-758-3611)



Application & Removal

All Skudo Tack-Mat products are easily applied by peeling off the release paper and pressing down onto the surface. Apply seam tape to the overlap joints to firmly secure. Simply peel up Tack-Mat leaving a clean, undamaged surface.



For detailed step-by-step Tack-Mat application directions and video, please visit our website: www.skudousa.com/how-to-apply/skudo-tack-mat/



Easy Application

Heavy Traffic (HT) Tack-Mat Product Data

- Width : 40"
- Length : 165'
- Surface Area : 550 SF
- Mat Thickness : 1/16"
- Roll Weight : 90 lbs
- Color : Orange
- Product SKU : TM-HT-3.3-165

Limitations

- **INTERIOR USE ONLY.** Skudo HT Tack-Mat is intended for interior use only and is not suited for areas that will be exposed to inclement weather and wind. If exposure to the elements is a concern, Skudo recommends the Heavy Traffic (HT) Commercial Mat System. Please consult with your Skudo representative for more details.
- **All adhesives have the potential to lift finished coatings or paint depending on the condition and age of the surface.** Testing a small piece in a non-critical area will help you judge suitability for use.
- If applying to hardwood flooring, only use Skudo Tack-Mat on sealed hardwood with a hard wearing factory finished surface (eg : Aluminum Oxide). If in question, please contact Skudo for suitability testing.
- **Skudo Tack-Mat should NOT be applied to:**
 - Polished Concrete
 - Concrete that has not fully cured
 - Limestone
 - Non-factory finished hardwood flooring
 - Any exterior surfaces

Please consult with your Skudo representative to determine which Skudo product is best for your project.

Innovative, purpose-built surface protection systems. This is all we do.

www.skudousa.com 1-888-SKUDO-11 (1-888-758-3611)



Heavy Traffic (HT) Tack-Mat Project Examples



Lobbies/Offices



Stairs



Staging Areas



Heavy Traffic Walkways



Remodel/Renovation



Commercial Interiors



Elevators



Bathrooms



Hallways/Corridors

Innovative, purpose-built surface protection systems. This is all we do.

www.skudousa.com 1-888-SKUDO-11 (1-888-758-3611)



Description

Skudo's Light Traffic (LT) Construction Tack-Mat offers outstanding temporary surface protection that is easy to apply to both vertical and horizontal indoor surfaces, around corners such as stairs and door jambs, on countertops, cabinets, windows and more. LT Tack-Mat features a unique self-stick surface - simply peel the backing paper and apply.

LT Tack-Mat provides interior surface protection for commercial and residential projects for up to 12 months.

Benefits

- Strong bond with the surface blocks any dirt and debris from ever coming into contact with the protected substrate
- Impact protection from carts and foot traffic
- Stain proof protection from small spills of chemicals, solvents, paints, oils etc.
- Provides a slip resistant surface that is seamless and stationary
- Can be used in any temperature : -20°F to +200°F
- Easy to adjust or inspect surface, simply peel up and re-position

Uses

Protects all surfaces during construction / remodeling including:

- Marble, Granite, & Stone*
- Hardwood* and laminate
- Ceramic and Porcelain Tile
- Glass, Epoxies, and Metals
- Sheet Vinyl
- Vertical surfaces, such as walls, cabinets, doors, framing, and stairs
- Showers, bathtubs, and countertops

*Please see "Limitations" section (flip side)



Easy Application



Versatile usage



Protects from materials & dirt



Durable



Innovative, purpose-built surface protection systems. This is all we do.

www.skudousa.com 1-888-SKUDO-11 (1-888-758-3611)



Application & Removal

All Skudo Tack-Mat products are easily applied by peeling off the release paper and pressing down onto the surface. Simply peel up Tack-Mat leaving a clean, undamaged surface.



For detailed step-by-step Tack-Mat application directions and video, please visit our website:
www.skudousa.com/how-to-apply/skudo-tack-mat/



Easy Application

Light Traffic (LT) Tack-Mat Product Data

- Width : 40"
- Length : 165'
- Surface Area : 550 SF
- Mat Thickness : 1/16"
- Roll Weight : 50 lbs
- Color : Grey
- Product SKU : TM-LT-3.3-165

Limitations

- **INTERIOR USE ONLY.** Skudo LT Tack-Mat is intended for interior use only and is not suited for areas that will be exposed to inclement weather and wind. If exposure to the elements is a concern, Skudo recommends the Heavy Traffic (HT) Commercial Mat System. Please consult with your Skudo representative for more details.
- **All adhesives have the potential to lift finished coatings or paint depending on the condition and age of the surface.** Testing a small piece in a non-critical area will help you judge suitability for use.
- If applying to hardwood flooring, only use Skudo Tack-Mat on sealed hardwood with a hard wearing factory finished surface (eg : Aluminum Oxide). If in question, please contact Skudo for suitability testing.
- If applying vertically, space must be conditioned. Humidity can cause this system to release from the substrate.
- **Skudo Tack-Mat should NOT be applied to:**
 - Polished Concrete
 - Concrete that has not fully cured
 - Limestone
 - Hardwood floors finished onsite
 - Any exterior surfaces

Please consult with your Skudo representative to determine which Skudo product is best for your project.

Innovative, purpose-built surface protection systems. This is all we do.

www.skudousa.com 1-888-SKUDO-11 (1-888-758-3611)



Light Traffic (LT) Tack-Mat Project Examples



Open Floors



Stairs



Residential



Office



Doors & Vertical Surfaces



Staging & Storage Areas



Countertops



Lobbies



Privacy Screen

Innovative, purpose-built surface protection systems. This is all we do.

www.skudousa.com 1-888-SKUDO-11 (1-888-758-3611)



Extreme Protection – High Impact

The HIGH IMPACT version of the Skudo Tack-Mat offers superior impact resistance in addition to the usual temporary surface protection expected from Skudo's products. Like all Skudo Tack-Mat products, the HIGH IMPACT product features a unique repositionable self-stick backing - simply peel the backing paper and apply. The HIGH IMPACT Tack-Mat can be used on both horizontal and vertical interior surfaces, around corners such as stairs and door jambs, on countertops, cabinets, windows and more.

HIGH IMPACT Tack-Mat provides interior surface protection for commercial and residential projects for up to 12 months.

Benefits

- Superior impact resistance for delicate surfaces
- Strong bond blocks dirt and debris from contact with the protected surface
- Stain resistant protection against chemicals, solvents, paints, oils and other liquids
- Provides a durable, slip resistant stationary surface
- Can be used in any temperature : -20°F to +200°F
- Easy to adjust or inspect surface, simply peel up and re-position

Uses

Protects all surfaces during construction / remodeling including:

- Marble, Granite, & Stone*
- Hardwood* and laminate
- Ceramic and Porcelain Tile
- Glass, Epoxies, and Metals
- Sheet Vinyl
- Vertical surfaces, such as walls, cabinets, doors, framing, and stairs
- Showers, bathtubs, and countertops

*Please see "Limitations" section (pg 2)



Superior Impact Protection



Versatile usage



Protects many surface types



Perfect for high traffic zones

Innovative, purpose-built surface protection systems. This is all we do.

www.skudousa.com 1-888-SKUDO-11 (1-888-758-3611)



Application & Removal

All Skudo Tack-Mat products are easily applied by peeling off the release paper and pressing down onto the surface. Simply peel up Tack-Mat leaving a clean, undamaged surface.



For detailed step-by-step Tack-Mat application directions and video, please visit our website: www.skudousa.com/how-to-apply/skudo-tack-mat/



Easy Application

High Impact (HI) Tack-Mat Product Data

- Width : 40"
- Length : 65'
- Surface Area : 215 SF
- Mat Thickness : 1/6"
- Roll Weight : 42 lbs
- Color : Grey
- Product SKU : TM-HI-3.3-65-IMPACT

Limitations

- **INTERIOR USE ONLY.** Skudo HI Tack-Mat is intended for interior use only and is not suited for areas that will be exposed to inclement weather and wind. If exposure to the elements is a concern, Skudo recommends the Heavy Traffic (HT) Commercial Mat System. Please consult with your Skudo representative for more details.
- **All adhesives have the potential to lift finished coatings or paint depending on the condition and age of the surface.** Testing a small piece in a non-critical area will help you judge suitability for use.
- If applying to hardwood flooring, only use Skudo Tack-Mat on sealed hardwood with a hard wearing factory finished surface (eg : Aluminum Oxide). If in question, please contact Skudo for suitability testing.
- If applying vertically, space must be conditioned. Humidity can cause this system to release from the substrate.
- **Skudo Tack-Mat should NOT be applied to:**
 - Polished Concrete
 - Concrete that has not fully cured
 - Limestone
 - Non-factory finished hardwood flooring
 - Any exterior surfaces

Please consult with your Skudo representative to determine which Skudo product is best for your project.

Innovative, purpose-built surface protection systems. This is all we do.

www.skudousa.com 1-888-SKUDO-11 (1-888-758-3611)



COUNTER MAT



Description

Skudo Counter-Mat has been specifically designed to provide perfect protection for countertops, kitchen/bath surfaces, and other small areas during construction. Counter-Mat's labor-saving 27 inch width reduces the need to cut down rolls, helping to eliminate project waste. Also, like all Skudo Tack-Mat products, Counter-Mat features a unique self-stick surface - simply peel the backing paper and apply.

Skudo Counter-Mat provides interior surface protection for commercial and residential projects for up to 12 months.

Benefits

- Strong bond with the surface blocks dirt and debris from coming into contact with the protected substrate
- Impact protection from carts, ladders, tools, and more
- Stain proof protection from small spills of chemicals, solvents, paints, oils etc.
- Seamless and stationary - won't move out of place
- Can be used in any temperature : -20°F to +200°F
- Easy to adjust or inspect surface, simply peel up and re-position

Uses

Protects all surfaces during construction / remodeling including:

- Marble, Granite, and Stone*
- Ceramic and Porcelain Tile
- Vinyl, laminate, and hardwood*
- Glass
- Metal surfaces, such as stainless steel and aluminum

*Please see "Limitations" section (pg 2)



Sized for countertops



Impact protection



Perfect for small areas



Protection from equipment

Innovative, purpose-built surface protection systems. This is all we do.

www.skudousa.com 1-888-SKUDO-11 (1-888-758-3611)



COUNTER MAT



Application & Removal

All Skudo Tack-Mat products are easily applied by peeling off the release paper and pressing down onto the surface. Simply peel up Tack-Mat leaving a clean, undamaged surface.



For detailed step-by-step Tack-Mat application directions and video, please visit our website: www.skudousa.com/how-to-apply/skudo-tack-mat/



Easy Application

Counter Mat Product Data

- Width : 27"
- Length : 82'
- Surface Area : 184 SF
- Mat Thickness : 1/16"
- Roll Weight : 15 lbs
- Color : Grey
- Product SKU : TM-LT-2.25-82-COUNTER

Limitations

- **INTERIOR USE ONLY.** Skudo Tack-Mat is intended for interior use only and is not suited for areas that will be exposed to inclement weather and wind. If exposure to the elements is a concern, Skudo recommends the Heavy Traffic (HT) Commercial Mat System. Please consult with your Skudo representative for more details.
- **All adhesives have the potential to lift finished coatings or paint depending on the condition and age of the surface.** Testing a small piece in a non-critical area will help you judge suitability for use.
- If applying to hardwood flooring, only use Skudo Tack-Mat on sealed hardwood with a hard wearing factory finished surface (eg : Aluminum Oxide). If in question, please contact Skudo for suitability testing.
- If applying vertically, space must be conditioned. Humidity can cause this system to release from the substrate.
- **Skudo Tack-Mat should NOT be applied to:**
 - Polished Concrete
 - Concrete that has not fully cured
 - Limestone
 - Non-factory finished hardwood flooring
 - Any exterior surfaces

Please consult with your Skudo representative to determine which Skudo product is best for your project.

Innovative, purpose-built surface protection systems. This is all we do.

www.skudousa.com 1-888-SKUDO-11 (1-888-758-3611)



EDGE PROTECT



Description

Skudo Edge Protect Tack-Mat has been specifically designed and sized to protect window frames, ledges, railing, door jambs, and other indoor framing and edges during construction. With both 8 inch and 12 inch width rolls available, there is no longer a need to cut down rolls which helps to save time, labor, and waste. Also, like all Skudo Tack-Mat products, Edge Protect features a unique self-stick surface - simply peel the backing paper and apply.

Skudo Edge Protect provides interior surface protection for commercial and residential projects for up to 12 months.

Benefits

- Strong bond with the surface blocks any dirt and debris from ever coming into contact with the protected substrate
- Impact protection from carts, ladders, tools, and more
- Stain proof protection from small spills of chemicals, solvents, paints, oils etc.
- Seamless and stationary - won't move out of place
- Can be used in any temperature : -20°F to +200°F
- Easy to adjust or inspect surface, simply peel up and re-position

Uses

Protects all edges during construction / remodeling including:

- Glass & Metal framing, ledges, and railing
- Ceramic and Porcelain Tile
- Marble, Granite, and Stone*
- Vinyl, Laminate, and Hardwood*

*Please see "Limitations" section (pg 2)



Perfect for framing



Peel up and re-apply



Protect edges from damage



Durable



Innovative, purpose-built surface protection systems. This is all we do.

www.skudousa.com 1-888-SKUDO-11 (1-888-758-3611)

V 2.2 3.4.20



EDGE PROTECT



Application & Removal

All Skudo Tack-Mat products are easily applied by peeling off the release paper and pressing down onto the surface. Simply peel up Tack-Mat leaving a clean, undamaged surface.



For detailed step-by-step Tack-Mat application directions and video, please visit our website:
www.skudousa.com/how-to-apply/skudo-tack-mat/



Easy Application

Edge Protect Tack-Mat Available Sizes & Product Data

- **Dimensions: 8.5"W x 50'L**
- Square Footage: 33.3 sq. ft./roll
- Product #TM-EP-8i-50
- Color: Grey
- Weight: 3.5 lbs./roll
- Thickness: 1/16"
- **Dimensions: 12"W x 82'L**
- Square Footage: 82 sq. ft./roll
- Product #TM-EP-12i-82
- Color: Grey
- Weight: 8.5 lbs./roll
- Thickness: 1/16"

Limitations

- **INTERIOR USE ONLY.** Skudo Tack-Mat is intended for interior use only and is not suited for areas that will be exposed to inclement weather and wind. If exposure to the elements is a concern, Skudo recommends the Heavy Traffic (HT) Commercial Mat System. Please consult with your Skudo representative for more details.
- **All adhesives have the potential to lift finished coatings or paint depending on the condition and age of the surface.** Testing a small piece in a non-critical area will help you judge suitability for use.
- If applying to hardwood flooring, only use Skudo Tack-Mat on sealed hardwood with a hard wearing factory finished surface (eg : Aluminum Oxide). If in question, please contact Skudo for suitability testing.
- If applying vertically, space must be conditioned. Humidity can cause this system to release from the substrate.
- **Skudo Tack-Mat should NOT be applied to:**
 - Polished Concrete
 - Concrete that has not fully cured
 - Limestone
 - Non-factory finished hardwood flooring
 - Any exterior surfaces

Please consult with your Skudo representative to determine which Skudo product is best for your project.

Innovative, purpose-built surface protection systems. This is all we do.

www.skudousa.com 1-888-SKUDO-11 (1-888-758-3611)

V 2.2 3.4.20



Skudo Tack-Mat Application Guide

This guide is applicable to the following product lines: Skudo Heavy Traffic (HT) Tack-Mat, Light Traffic (LT) Tack-Mat, High Impact (HI) Tack-Mat, Edge Protect Tack-Mat, and Counter Mat

IMPORTANT - Read Before Applying:

- **Skudo Tack-Mat should NOT be applied to:**
 - Concrete
 - Limestone
 - Non-factory finished hardwood flooring
- **INTERIOR USE ONLY.** All Skudo Tack-Mat products are intended for interior use only and is not suited for areas that will be exposed to inclement weather and wind. If exposure to the elements is a concern, Skudo recommends the Heavy Traffic (HT) Commercial Mat System. Please consult with your Skudo representative for more details.
- **All adhesives have the potential to lift finished coatings or paint depending on the condition and age of the surface.**

Testing a small piece in a non-critical area will help you judge suitability for use.

- If applying to hardwood flooring, only use Skudo Tack-Mat on sealed hardwood with a hard wearing factory finished surface (eg : Aluminum Oxide). If in question, please contact Skudo for suitability testing.
- Tack Mat can be applied to vertical surfaces. However, space must be conditioned as humidity can cause this system to release from the substrate
- **Always consult with your Skudo Representative to determine which Skudo product is best suited for your project.**



STEP 1

Peel back 3 to 4 feet of the release paper from the back of the mat. Fold this back underneath the Tack-Mat roll.



STEP 2

Align the roll to ensure a straight application. Attach the tacky side to the surface and press in the mat firmly.



STEP 3

When first roll is completed, begin the second row, overlapping the mat by 2 inches. On HT Tack-Mat and also for extra durability on LT and HI Tack-Mat, apply vinyl or duct tape to the overlap joints.



STEP 4

Continue installing until the entire area is protected. Tack-Mat can be lifted for inspection or to smooth out wrinkles and press back into place. Your surface is now protected.



APPLICATION ON STAIRS

Start at the bottom and pull the release paper up while moving the roll up the stairs. Press the Tack-Mat onto all the treads and risers.



USE ON VERTICAL SURFACES

For use on vertical surfaces, simply peel the release paper and fully press the Tack-Mat into the surface to be protected. Please note that for vertical application, the space must be conditioned in order to prevent the mat from prematurely separating from the substrate.



For detailed step-by-step Tack-Mat application directions and video, please visit our website.

Innovative, purpose-built surface protection systems. This is all we do.

www.skudousa.com 1-888-SKUDO-11 (1-888-758-3611)

{ Tab Here ----->
“ALL-TERRAIN MAT” }



All-Terrain Mat

All-Terrain Mat provides an extremely durable traffic zone on loose and unprepared ground on construction sites for use by workers, contractors, and their clients.

All-Terrain Mat provides a heavy duty surface (1/2 inch thick) with a free draining structure that allows dirt and water to pass through. This provides a very high level of slip resistance for both wet and dry conditions.

All-Terrain Mat offers excellent durability and resistance to heavy wear & tear.

Uses:

- Provides a safe walkway over gravel, rocks, mud, snow & ice.
- Excellent walk off mat to keep your site & job trailers clean.
- Directs traffic safely through heavy construction zones.
- Anti-fatigue properties for workers.

Features:

- Extremely durable construction that allows water & soil to pass through the mat.
- Thick & heavy so it stays in place in challenging conditions.
- Test-proven protection against flame & freeze. (FMVSS 302-1998)
- Can be pegged down as needed.

For jobsites with rough terrain, heavy rain, mud, snow and ice, Skudo's All-Terrain Mat is the solution.



Traps Dirt & Debris



Use over Mud & Rocks



Perfect for Beach Access Paths



Thick, Heavy Duty Surface



Perfect for Workers, Contractors, & Clients



Stays in Place Over Harsh Terrain



Safely Direct Traffic through a Jobsite - including TPO Roofs

Innovative, purpose-built surface protection systems. This is all we do.

www.skudousa.com 1-888-SKUDO-11 (1-888-758-3611)



All-Terrain Mat Product Details

Part # = AT-3K-3.3-33-ORANGE

Dimensions:

- Mat Width = 3.3 feet
- Mat Length = 33 feet
- Mat Weight = 86 lbs per roll / 0.8 lb. per sq. ft. (approx)
- Roll Diameter = 16 in. (approx)
- Product Thickness = 0.5 in. (approx)

Composition: Specially designed non-absorbent Vinyl loop coils extruded from 100% PVC and thermally bonded. DOP Free.

Appearance: Orange vinyl loop coiled mat

Fire resistance: In accordance with -
US CPSC 16 CFR Part 1631 (FF2-70)

Frost Resistance: Withstand -13°F without break

Tensile Strength: In accordance with ASTM D5034-2009
Crosswise - 3997N
Lengthwise - 3923N

Tear Strength: In accordance with ASTM D5034-2009
Crosswise - 1342N
Lengthwise - 1216N

Slip Resistance: In reference to to GB/t 4100-2006
Friction Coefficient (DRY) - 0.685
Friction Coefficient (WET) - 0.580

REACH: In accordance with EC No 1907/2006 - PASS

Packaging: 9 rolls per pallet



Innovative, purpose-built surface protection systems. This is all we do.

www.skudousa.com 1-888-SKUDO-11 (1-888-758-3611)



All-Terrain Mat Project Examples



Water Run-Off Areas



Outside Construction Trailers



Walkways - Beach



Walkways - Loose Ground



Outdoor Stairs



Heavy Equipment



Ramps

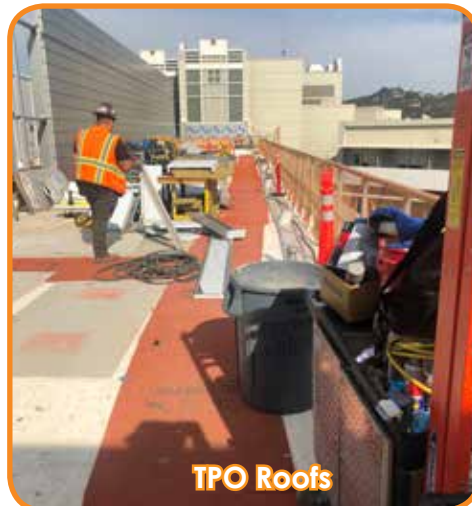

TPO Roofs



Walkways - Interior

Innovative, purpose-built surface protection systems. This is all we do.

www.skudousa.com 1-888-SKUDO-11 (1-888-758-3611)

{ Tab Here ----->
“SKUDOBOARD” }



Description

SkudoBoard is a heavy duty, synthetic, rigid board that provides superior protection under forklift and general construction traffic. Use wherever you would protect your surfaces with Masonite or plywood. Ideal for use under work stations - pipe cutting, finish carpentry, painting.

The textured surface of SkudoBoard is fire retardant, water resistant and resists curling and warping - reducing safety hazards on your jobsite. The high compression strength protects from dropping objects and spreads the load under forklifts, keeping your floors safe. It can also be used for extreme vertical protection.

SkudoBoard is also available in a **Fabric Back** version - which features a unique fabric underside to make it safer for surface types like tile, stone, marble, vinyl, hardwood, etc. without fear of damage, chips, and scratches.

Features & Benefits

- Water resistant, can be used on exterior surfaces
- Fire Retardant (ATSM E Class 1, 16 CFR 1630)
- Test-proven slip resistance in wet conditions (ANSI/NFSI B101.3-2012)
- Extremely high impact resistance – spreads impact loads
- Ideal for use under work stations – i.e. pipe cutting, finish carpentry, painting.
- Ideal for forklift and material cart protection
- Well suited for protecting floors from work station traffic and debris
- Light weight, easy to handle and reusable
- Replaces curling Masonite and plywood
- Far superior to cardboard protection products
- Fabric Back version now available for additional protection from surface damage



High impact protection



Water resistant, resists curling and warping



Use under ladders, carts, and workstations



Fabric Back version available for additional protection

Innovative, purpose-built surface protection systems. This is all we do.

www.skudousa.com 1-888-SKUDO-11 (1-888-758-3611)



SkudoBoard Available Versions & Product Data

SkudoBoard (Standard)

- Dimensions: 4'W x 8'L
- Square Footage: 32 sq. ft./board
- Product #BOARD-HT-FR-4x8-1500
- Weight: 10 lbs./sheet
- Thickness: 5/16"
- Color: Grey

SkudoBoard - Fabric Back

- Dimensions: 4'W x 8'L
- Square Footage: 32 sq. ft./board
- Product #BOARD-HT-FR-4x8-FABRIC
- Weight: 10 lbs./sheet
- Thickness: 7/16"
- Color: Grey

SkudoBoard Technical Data

5 mm, 1500 g/m²

Property	Test Standard	Units	Result Average Value	Standard Deviation
Board Thickness		mm	5.00	0.10
Unit Weight		g/m ²	1524	66
Flexural Strength, MD	ASTM D790 (Modified)	psi	1433	87
Flexural Strength, TD	ASTM D790 (Modified)	psi	1344	78
Flexural Modulus, MD	ASTM D790 (Modified)	Kpsi	120	9
Flexural Modulus, TD	ASTM D790 (Modified)	Kpsi	112	5
Gardner Impact Mean-Failure Impact	ASTM D5420	in	4.3	0.9
Flat Crush Resistance	ISO 3035 TAPPI-825	psi	> 1000	
Edge Crush Resistance	ISO 3037 TAPPI-811	lb./in	88	22

Note:

1. Flexural Test: 12" x 12" sample with 10" span, 3-point bending
2. Gardner Impact Test: 8 lb. steel-rod impact mass
3. MD: Machine Direction
4. TD: Transverse Direction
5. Kpsi = 10³ psi

Innovative, purpose-built surface protection systems. This is all we do.

www.skudousa.com 1-888-SKUDO-11 (1-888-758-3611)



INTERLOCK



Description

SkudoBoard INTERLOCK is a heavy duty, synthetic, rigid board that provides superior protection under forklift and general construction traffic. The interlocking tabs also keep the board from slipping and moving out of place.

Use SkudoBoard Interlock wherever you would traditionally protect your surfaces with Masonite or plywood. Ideal for use under work stations - pipe cutting, finish carpentry, painting. Easy to layout and repack for quick mobilization on after-hours projects.

The textured surface of SkudoBoard INTERLOCK provides high slip resistance in addition to being fire retardant and water resistant. SkudoBoard INTERLOCK does not curl or warp - reducing safety hazards on your jobsite. The high compression strength protects from dropping objects and spreads the load under forklifts, keeping your floors safe. It can also be used for extreme vertical protection.

Features & Benefits

- Interlocking tabs keep SkudoBoard securely in place
- Water resistant, can be used on exterior surfaces
- Replaces curling Masonite and plywood
- Fire Retardant (ATSM E Class 1, 16 CFR 1630)
- Test-proven slip resistance in wet conditions (ANSI/NFSI B101.3-2012)
- Extremely high impact resistance – spreads impact loads
- Ideal for use under work stations – i.e. pipe cutting, finish carpentry, painting.
- Ideal for forklift and material cart protection
- Well suited for protecting floors from jobsite traffic and debris
- Light weight, easy to handle and reusable
- Far superior to cardboard protection products
- Edge pieces included to fill in gaps when placing against walls



Extremely high impact resistance



Interlocking tabs hold product securely in place



Superior protection under forklift and construction traffic



Edge pieces fill in gaps along walls

Innovative, purpose-built surface protection systems. This is all we do.

www.skudousa.com 1-888-SKUDO-11 (1-888-758-3611)

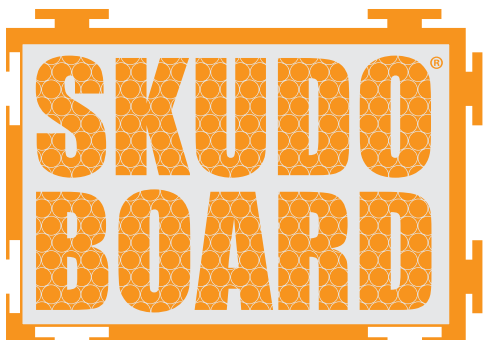

INTERLOCK

SkudoBoard INTERLOCK Product Data

SkudoBoard Interlock

- Dimensions: 3.75' x 3.75'
- Square Footage: 14 sq. ft./board
- Product #BOARD-HT-FR-3.75-INTRL
- Weight: 4 lbs/sheet
- Thickness: 1/8"
- Color: Light Gray



Fire retardant, water & slip resistant

SkudoBoard Technical Data

5 mm, 1500 g/m²

Property	Test Standard	Units	Result Average Value	Standard Deviation
Board Thickness		mm	5.00	0.10
Unit Weight		g/m ²	1524	66
Flexural Strength, MD	ASTM D790 (Modified)	psi	1433	87
Flexural Strength, TD	ASTM D790 (Modified)	psi	1344	78
Flexural Modulus, MD	ASTM D790 (Modified)	Kpsi	120	9
Flexural Modulus, TD	ASTM D790 (Modified)	Kpsi	112	5
Gardner Impact Mean-Failure Impact	ASTM D5420	in	4.3	0.9
Flat Crush Resistance	ISO 3035 TAPPI-825	psi	> 1000	
Edge Crush Resistance	ISO 3037 TAPPI-811	lb./in	88	22

Note:

1. Flexural Test: 12" x 12" sample with 10" span, 3-point bending
2. Gardner Impact Test: 8 lb. steel-rod impact mass
3. MD: Machine Direction
4. TD: Transverse Direction
5. Kpsi = 10³ psi

Innovative, purpose-built surface protection systems. This is all we do.

www.skudousa.com 1-888-SKUDO-11 (1-888-758-3611)



COLUMN GUARD



Description

SkudoBoard COLUMN GUARD is a heavy duty, synthetic, flexible version of SkudoBoard product line that provides superior protection to columns and pillars during construction. Column Guard protects the surface from damage from splatter, spills, scuff marks, and scratches, carts, supplies and equipment.

The textured surface of Column Guard is water resistant and won't curl, warp, or unravel - reducing safety hazards on your jobsite. Use wherever you would protect your columns with cardboard, plastic, masonite or plywood.

Features & Benefits

- Water resistant, approved for exterior use
- Replaces curling Masonite and plywood
- Extremely high impact resistance
- Ideal for forklift and material cart protection
- Well suited for protecting columns from jobsite traffic and impact
- Light weight, easy to handle and reusable
- Far superior to cardboard and plastic protection products

SkudoBoard Column Guard Product Data

- Dimensions: 4' x 250'
- Square Footage: 1000 sq. ft./roll
- Product #BOARD-COLUMN-4x250-220#
- Weight: 200 lbs/roll
- Thickness: 1/8"
- Color: Black, Grey



Extremely high impact resistance



Stays in place - won't unravel



Easy to handle, reusable



No damage from jobsite materials

Innovative, purpose-built surface protection systems. This is all we do.

www.skudousa.com 1-888-SKUDO-11 (1-888-758-3611)



SkudoBoard Project Examples



Vertical Protection



Machinery



Scaffolding



Mud and Spilled Materials



Driveways/Walkways



Column Protection



Shopping Centers

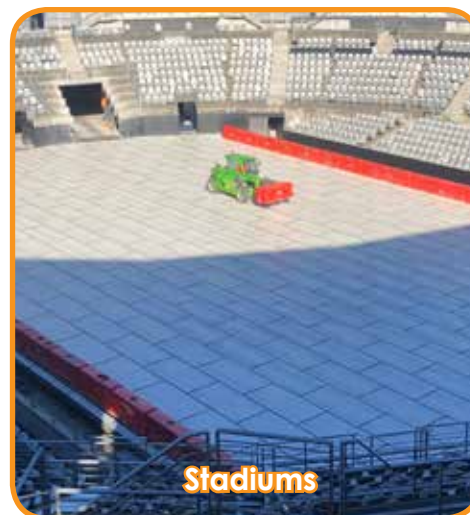

Stadiums



Staging/Storage Areas

Innovative, purpose-built surface protection systems. This is all we do.

www.skudousa.com 1-888-SKUDO-11 (1-888-758-3611)

{ Tab Here ----->
“GLASS ADVANCED” }



Description

Skudo Glass Advanced is the perfect solution for all construction projects that require temporary window and glass protection from start to finish. Tough enough to withstand cement and paint splatter, Skudo Glass Advanced will protect valuable glass and frames for up to 12 months.

Benefits

- Resists job site spills and splatter, including cement, paint and stucco
- Can be applied at manufacturer to provide protection during transit
- Fire Resistant to withstand welding and grinding sparks
- Simple application with spray or roller
- Easy peel off removal
- Available in **blue (transparent)** or **white (opaque)** finish

Uses

Skudo Glass Advanced can be applied to:

- Glass, Windows, Curtain Walls, Panels and Balustrades
- Metals, such as Stainless Steel and Aluminum
- Cladding

Skudo Glass Advanced is **not** suitable to be applied on acrylic surfaces, but it can be used on 'Low-e' (low emissivity) glass.



Innovative, purpose-built surface protection systems. This is all we do.

www.skudousa.com 1-888-SKUDO-11 (1-888-758-3611)



APPLICATION GUIDE

SIDE 1



BEFORE YOU BEGIN APPLICATION...

- 1. Test Area & Test Peel** – You must always apply Skudo Glass Advanced to a small area to test the substrate's suitability. You must ensure that all substrates are covered. Allow the product to dry for 48 hours, and then check that the product will peel away from each substrate.

NOTE - Do **not** apply Skudo Glass Advanced to Acrylic surfaces. It will bond permanently.
- 2. Masking** – Mask all areas that you don't intend to coat with Skudo Glass Advanced. Items such as locks, handles and vents should always be masked with a suitable tape. Always remove the tape once the product has been applied and is still wet.
- 3. Weather** – Skudo Glass Advanced cannot be applied if the temperature is below freezing or in rainfall. If the surface is likely to be exposed to direct rainfall before the product has dried, do not apply.
- 4. Stir Product** – Remove the lid and stir the product thoroughly before use. Skudo Glass Advanced has a 12 month shelf life - see product's label for more detailed information. A skin may have formed when the lid is removed for the second time. Simply cut the skin away and then stir the Skudo product. Do not stir the skin into the product.
- 5. Wet Film Thickness** – Ensure you have a wet film gauge. Skudo Glass Advanced requires a minimum wet film thickness (WFT) of 10 Mils.

APPLICATION BY ROLLER

We recommend that you use a 3/8 Nap lambswool roller for application. Ensure that you have followed the "Before you Begin Application" section.



- Once you have masked off the area, apply a base coat of Skudo to the substrate paying particular attention to vulnerable areas such as corners. Allow to dry for 15 minutes or until coating is tacky.
- Apply a second, thicker coating, again paying particular attention to corners. If the coating is too thin in these areas it will be difficult to remove. Dry time will take up to 15 minutes, depending on weather conditions.
- Use a wet film gauge to check the coating's wet film thickness (WFT) is at least 10 Mils.
- Remove the masking tape while the product is still wet. This helps to achieve a good thick edge that is easier to peel when the product is no longer required.



- Leave to dry in a rain free environment and allow 2 hours at room temperature to dry. The product will gain maximum strength after 3 days.
- After application, rollers and any other equipment should be washed thoroughly in cold water.
- When required, Skudo is removed by hand peeling. Do not remove in freezing conditions - the product will be brittle and will not peel properly.
- Repair:** If the coating is damaged at a later date, a new coating of Skudo Glass Advanced can be applied over the damaged area. It will bond to itself and provide seamless protection.

Innovative, purpose-built surface protection systems. This is all we do.

www.skudousa.com 1-888-SKUDO-11 (1-888-758-3611)



APPLICATION GUIDE

SIDE 2



APPLICATION BY SPRAY

If you use an airless spray gun, we recommend a minimum tip size of 0.021" (eg: 321, 323 or 325) and that you use a shield to protect against overspray on brick work, stucco, etc. Ensure that you have followed the "Before you Begin Application" section.



1. You need to purge the spray equipment before you begin application. First place the inlet suction hose into the Skudo container and purge the airless spray pump with material. Then purge the airless spray gun and test the spray pattern.



2. Point the nozzle at the area you wish to protect and hold the spray gun 12-15 inches from the substrate. Use a shield to prevent overspray.



3. Release the safety catch and start spraying in a horizontal direction. Keep the gun at right angles to the surface. This means moving your entire arm back and forth rather than flexing the wrist.



4. Release the trigger at the end of each stroke. Then depress the trigger and overlap the previous pass by 50%. Continue in this fashion for consistent coverage working down the substrate.



5. When the surface is fully covered, repeat with the spray process in a vertical direction. Care should be taken to ensure that corners and inside edges are coated thoroughly. If the coating is too thin in these areas it may become difficult to remove.



6. Use a wet film gauge to check that the coating's wet film thickness (WFT) is at least 10 Mils. Remove any masking tape while the product is still wet.



7. Once spraying is complete, clean the gun using cold water. Failure to clean the gun will result in problems next time the gun is used.



8. Leave to dry in a rain free environment and allow 2 hours at room temperature to dry. The product will gain maximum strength after 3 days.



9. When required Skudo is removed by hand peeling. Do not remove in freezing conditions - the product will be brittle and not peel properly. The coating can be condensed into a small ball and disposed of.



Repair: If the coating is damaged at a later date, a new coating of Skudo Glass Advanced can be applied over the damaged area. It will bond to itself and provide seamless protection.



Innovative, purpose-built surface protection systems. This is all we do.

www.skudousa.com 1-888-SKUDO-11 (1-888-758-3611)



Glass Advanced Project Examples



High-Rise



Skylights



Residential



Storefronts



Manufacturing - Buildings



Manufacturing - Steel Tanks



Restaurants



Commercial Buildings



Grinding/Welding

Disclaimer: Skudo Glass Advanced should **not** be applied to acrylic surfaces. It will bond permanently. Skudo Glass Advanced can be used on Low-e (low emissivity) glass.

Innovative, purpose-built surface protection systems. This is all we do.

www.skudousa.com 1-888-SKUDO-11 (1-888-758-3611)

{ Tab Here ----->
“SDS SHEETS”]



Product Name: HT Commercial Mat

Issue Date: Jan 2012
Issued By: Skudo LLC

1. IDENTIFICATION

Product Name: Skudo HT Commercial Mat
Product Code: CM-HT-6.5-123
Product Use: Temporary Surface Protection

Company Name: Skudo LLC

Address: 11120 Zodiac Ln
Dallas, TX 75229

Telephone: 1-888-758-3611 (1-888-SKUDO-11)
Fax: 972-993-0700

2. HAZARDS IDENTIFICATION

Main hazards: No significant hazard.

3. COMPOSITION / INFORMATION ON INGREDIENTS

<u>NAME:</u>	<u>CAS:</u>	<u>PROPORTION:</u>
Polyethylene terephthalate	25 038-59-9	40-60%
Styrene/Acrylate	confidential	15-25%
Bitumen	8052-42-4	0-5%
Alumina tri-hydrate	21645-51-2	20-35%

4. FIRST AID MEASURES

Swallowed:	No special measures necessary.
Eye:	Rinse with plenty of water, if persistent irritation, see a physician.
Skin:	Wash skin thoroughly with soap and water.
Inhaled:	Inhalation of fiber fly, dust and finish decomposition products should be avoided by fresh air ventilation. In case of coughing or other symptoms, the person should seek fresh air and, if necessary a physician.
First Aid Facilities:	Eye wash fountains and safety showers should be easily accessible.

5. FIRE-FIGHTING MEASURES

Fire hazards:	Product will burn in a fire. Auto ignition temperature: 960 deg F (DIN 51794) Thermal decomposition: > 570 deg F
Fire/Explosion Hazard:	Fiber dust and fly could present a fire hazard at sufficient concentrations. Remove ignition sources. Beware of electrostatic charges.
Fire Fighting Procedures:	Wear full body protective clothing and self-contained breathing apparatus. Water spray, foam, CO ² or dry chemical. Do not use water if fire is caused by an electrical short circuit.

6. ACCIDENTAL RELEASE MEASURES

Personal precautions:	Refer to section 8 of SDS for personal protection details.
------------------------------	--

7. HANDLING AND STORAGE

Storage Precautions:	Store in a dry place. Store away from foodstuffs, clothing and keep out of reach of children.
-----------------------------	---

8. EXPOSURE CONTROLS / PERSONAL PROTECTION

Acute - Swallowed:	No special measures necessary.
Acute – Eye	Rinse with plenty of water, if persistent irritation, see a physician.
Acute - Skin:	Prolonged or repeated contact with skin may result in irritation or rash.
Acute – Inhaled:	Inhalation hazards of this product are negligible pending possible imposition of threshold limit values. Therefore no special precautionary measures are necessary.
Chronic:	Principal routes of exposure are usually by skin contact with the material. Prolonged or repeated skin contact with bare skin may cause drying, cracking, irritation and possible dermatitis if sufficient water is present to extract surfactants from the coating.
Respirator Type: (AS 1716)	Not required for normal operations, but where work practice or other means exposure reduction is not adequate, approved respirator may be necessary to prevent over exposure by inhalation.
Eye Protection:	Safety goggles for cutting and handling is recommended.
Glove Type:	Standard work gloves for frequent handling.
Clothing:	Overalls.

9. PHYSICAL AND CHEMICAL PROPERTIES

Appearance: Orange coated NW fabric
Odor: odorless
Form: solid

10. STABILITY AND REACTIVITY

Boiling Point: Not applicable
Vapor Pressure: Not applicable
Solubility in Water: Not applicable
Stability: Stable
Specific Gravity: Not applicable
Flash Point: Not applicable

11. TOXICOLOGICAL INFORMATION

Acute toxicity: SKUDO HT COMMERCIAL MAT
ORL RAT LD50 >2000 mg/kg
Routes of exposure: Refer to section 4 of SDS for routes of exposure and corresponding symptoms.

12. ECOLOGICAL INFORMATION

Hazardous Decomposition or Byproducts: Carbon monoxide, carbon dioxide and low molecular weight organic Compounds depending on temperature and air supply.

13. DISPOSAL CONSIDERATIONS

Disposal: Bury in an approved landfill. Dispose of in accordance with Local, State and Federal Governments. If recycling is not possible, Polyester can be disposed of in a suitable refuse installation or incinerated subject to local regulations.

14. TRANSPORTATION INFORMATION

Classification: Not defined as Dangerous Goods by DOT for road or rail. Class 65

15. REGULATORY INFORMATION

Pkg & Labeling: No regulatory requirements for transport, storage and handling.

Note: The regulatory information given above only indicates the principal regulations specifically applicable to the product described in the safety data sheet. The user's attention is drawn to the possible existence of additional provisions which complete these regulations. Refer to all applicable national, international and local regulations or provisions.

16. OTHER INFORMATION

Disclaimer:

Skudo LLC makes no representation as to the completeness and accuracy of the data contained in this data sheet. It is the users obligation to evaluate and use this product safely and to comply with all relevant Federal, State and Local Government laws and regulations. Skudo LLC shall not be responsible for loss, damage or injury resulting from reliance upon or failure to adhere to any recommendations or information contained herein, from abnormal use of the material, or any hazard inherent in the nature of the material.

...End of Report...



Product Name: MT Commercial Mat

Issue Date: Jan 2012

Issued By: Skudo LLC

1. IDENTIFICATION

Product Name: Skudo MT Commercial Mat
Product Code: CM-MT-6.5-123
Product Use: Temporary Surface Protection

Company Name: Skudo LLC

Address: 11120 Zodiac Ln
Dallas, TX 75229

Telephone: 1-888-758-3611 (1-888-SKUDO-11)
Fax: 972-993-0700

2. HAZARDS IDENTIFICATION

Main hazards: No significant hazard.

3. COMPOSITION / INFORMATION ON INGREDIENTS

<u>NAME:</u>	<u>CAS:</u>	<u>PROPORTION:</u>
Polyethylene terephthalate	25 038-59-9	50-60%
Styrene/Acrylate	confidential	15-25%
Calcium carbonate	1317-65-3	25-35%

4. FIRST AID MEASURES

Swallowed:	No special measures necessary.
Eye:	Rinse with plenty of water, if persistent irritation, see a physician.
Skin:	Wash skin thoroughly with soap and water.
Inhaled:	Inhalation of fiber fly, dust and finish decomposition products should be avoided by fresh air ventilation. In case of coughing or other symptoms, the person should seek fresh air and, if necessary a physician.
First Aid Facilities:	Eye wash fountains and safety showers should be easily accessible.

5. FIRE-FIGHTING MEASURES

Fire hazards:	Product will burn in a fire. Auto ignition temperature: 960 deg F (DIN 51794) Thermal decomposition: > 570 deg F
Fire/Explosion Hazard:	Fiber dust and fly could present a fire hazard at sufficient concentrations. Remove ignition sources. Beware of electrostatic charges.
Fire Fighting Procedures:	Wear full body protective clothing and self-contained breathing apparatus. Water spray, foam, CO ² or dry chemical. Do not use water if fire is caused by an electrical short circuit.

6. ACCIDENTAL RELEASE MEASURES

Personal precautions:	Refer to section 8 of SDS for personal protection details.
------------------------------	--

7. HANDLING AND STORAGE

Storage Precautions:	Store in a dry place. Store away from foodstuffs, clothing and keep out of reach of children.
-----------------------------	---

8. EXPOSURE CONTROLS / PERSONAL PROTECTION

Acute - Swallowed:	No special measures necessary.
Acute – Eye	Rinse with plenty of water, if persistent irritation, see a physician.
Acute - Skin:	Prolonged or repeated contact with skin may result in irritation or rash.
Acute – Inhaled:	Inhalation of fiber fly, dust and finish decomposition products should be avoided by fresh air ventilation. In case of coughing or other symptoms, the person should seek fresh air and, if necessary a physician.
	Inhalation hazards of this product are negligible pending possible imposition of threshold limit values. Therefore no special precautionary measures are necessary.
Chronic:	Principal routes of exposure are usually by skin contact with the material. Prolonged or repeated skin contact with bare skin may cause drying, cracking, irritation and possible dermatitis if sufficient water is present to extract surfactants from the coating.
Respirator Type: (AS 1716)	Not required for normal operations, but where work practice or other means exposure reduction is not adequate, approved respirator may be necessary to prevent over exposure by inhalation.
Eye Protection:	Safety goggles for cutting and handling is recommended.
Glove Type:	Standard work gloves for frequent handling.

Clothing: Overalls.

9. PHYSICAL AND CHEMICAL PROPERTIES

Appearance: Yellow coated NW fabric
Odor: odorless
Form: solid

10. STABILITY AND REACTIVITY

Boiling Point: Not applicable
Vapor Pressure: Not applicable
Solubility in Water: Not applicable
Stability: Stable
Specific Gravity: Not applicable
Flash Point: Not applicable

11. TOXICOLOGICAL INFORMATION

Acute toxicity: SKUDO MT COMMERCIAL MAT
ORL RAT LD50 >2000 mg/kg

Routes of exposure: Refer to section 4 of SDS for routes of exposure and corresponding symptoms.

12. ECOLOGICAL INFORMATION

Hazardous Decomposition or Byproducts: Carbon monoxide, carbon dioxide and low molecular weight organic Compounds depending on temperature and air supply.

13. DISPOSAL CONSIDERATIONS

Disposal: Bury in an approved landfill. Dispose of in accordance with Local, State and Federal Governments. If recycling is not possible, Polyester can be disposed of in a suitable refuse installation or incinerated subject to local regulations.

14. TRANSPORTATION INFORMATION

Classification: Not defined as Dangerous Goods by DOT for road or rail. Class 65

15. REGULATORY INFORMATION

Pkg & Labeling: No regulatory requirements for transport, storage and handling.

Note: The regulatory information given above only indicates the principal regulations specifically applicable to the product described in the safety data sheet. The user's attention is drawn to the possible existence of additional provisions which complete these regulations. Refer to all applicable national, international and local regulations or provisions.

16. OTHER INFORMATION

Disclaimer:

Skudo LLC makes no representation as to the completeness and accuracy of the data contained in this data sheet. It is the users obligation to evaluate and use this product safely and to comply with all relevant Federal, State and Local Government laws and regulations. Skudo LLC shall not be responsible for loss, damage or injury resulting from reliance upon or failure to adhere to any recommendations or information contained herein, from abnormal use of the material, or any hazard inherent in the nature of the material.

...End of Report...

Skudo Concrete Base Coat

Version 1.0 Revision Date: 02/10/2016 MSDS Number: F000001879 Date of last issue: -
 Date of first issue: 02/10/2016

SECTION 1. IDENTIFICATION

Product name : Skudo Concrete Base Coat

Product code : CT-BASE-CONC-5 GAL (Pails) CT-BASE-CONC-IBC (IBC)

Manufacturer or supplier's details

Company name of supplier : Skudo LLC

Address : 11120 Zodiac Ln, Dallas, TX 75229

Telephone : (972) 993-0777

Telefax : (972) 993-0700

Emergency telephone number : (972) 993-0777

SECTION 2. HAZARDS IDENTIFICATION**GHS Classification**

Not a hazardous substance or mixture.

GHS Label element

Not a hazardous substance or mixture. **Other hazards** None known.

SECTION 3. COMPOSITION/INFORMATION ON INGREDIENTS**Hazardous components**

Chemical Name	CAS-No.	Concentration (%)
Modified cis 1,4 polyisoprene		30 – 60%
Water	7732-18-5	30 – 60%
Ammonia, Aqueous Solution	1336-21-6	0 – 2%
Calcium carbonate		0 – 35%
Titanium dioxide		0 – 3%
2-methyl-2H-isothiazol-3-one	2682-20-4	< 0.1 %

Skudo Concrete Base Coat

Version 1.0 Revision Date: 02/10/2016 MSDS Number: F000001879 Date of last issue: -
Date of first issue: 02/10/2016

SECTION 4. FIRST AID MEASURES

If inhaled	: Move to fresh air in case of accidental inhalation of vapours. : Oxygen or artificial respiration if needed. Call a physician or poison control centre immediately. If symptoms persist, call a physician.
In case of skin contact	: Wash off immediately with soap and plenty of water while removing all contaminated clothes and shoes. If symptoms persist, call a physician.
In case of eye contact	: In case of eye contact, remove contact lens and rinse immediately with plenty of water, also under the eyelids, for at least 15 minutes. Keep eye wide open while rinsing. Remove contact lenses. Seek medical advice.
If swallowed	: Do NOT induce vomiting. If symptoms persist, call a physician. If conscious, drink plenty of water. Never give anything by mouth to an unconscious person.
Most important symptoms and effects, both acute and delayed	: None known.

SECTION 5. FIREFIGHTING MEASURES

Suitable extinguishing media	: Foam Carbon dioxide (CO ₂) ABC powder Water mist
Specific hazards during firefighting	: Burning produces irritant fumes. Exposure to decomposition products may be a hazard to health. Cool closed containers exposed to fire with water spray. Do not allow run-off from fire fighting to enter drains or water courses.
Specific extinguishing methods	: Use extinguishing measures that are appropriate to local circumstances and the surrounding environment. Use water spray to cool unopened containers. Fire residues and contaminated fire extinguishing water must be disposed of in accordance with local regulations.
Special protective equipment for firefighters	: In the event of fire, wear self-contained breathing apparatus. Use personal protective equipment. Exposure to decomposition products may be a hazard to health.

Skudo Concrete Base Coat

Version 1.0 Revision Date: 02/10/2016 MSDS Number: F000001879 Date of last issue: -
 Date of first issue: 02/10/2016

SECTION 6. ACCIDENTAL RELEASE MEASURES

- Personal precautions, protective equipment and emergency procedures : Use personal protective equipment.
 Ensure adequate ventilation.
 Material can create slippery conditions.
 Use non-slip safety shoes in areas where spills or leaks can occur.
- Environmental precautions : Prevent further leakage or spillage if safe to do so.
 Do not let product enter drains.
 Do not allow contact with soil, surface or ground water.
 Do not allow uncontrolled discharge of product into the environment.
- Methods and materials for containment and cleaning up : Dam up.
 Soak up with inert absorbent material (e.g. sand, silica gel, acid binder, universal binder, sawdust).
 Sweep up and shovel.
 Pick up and transfer to properly labelled containers. Clean contaminated floors and objects thoroughly while observing environmental regulations.

SECTION 7. HANDLING AND STORAGE

- Advice on protection against fire and explosion : Keep away from open flames, hot surfaces and sources of ignition. No special protective measures against fire required.
- Advice on safe handling : Wear personal protective equipment.
 Handle with care.
 Take care to avoid waste and spillage when weighing, loading and mixing the product.
- Conditions for safe storage : No smoking.
 Keep in properly labelled containers.
 Observe label precautions.
 Keep containers tightly closed in a dry, cool and well-ventilated place.
- Materials to avoid : Do not freeze.
 Keep away from food and drink.
 Keep away from tobacco products.

SECTION 8. EXPOSURE CONTROLS/PERSONAL PROTECTION**Components with workplace control parameters**

Contains no substances with occupational exposure limit values.

Hazardous components without workplace control parameters

Components	CAS-No.
2-methyl-2H-isothiazol-3-one	2682-20-4

Skudo Concrete Base Coat

Version 1.0 Revision Date: 02/10/2016 MSDS Number: F000001879 Date of last issue: -
 Date of first issue: 02/10/2016

Engineering measures	: Handle only in a place equipped with local exhaust (or other appropriate exhaust). Maintain air concentrations below occupational exposure standards. Personal protective equipment
Respiratory protection	: No personal respiratory protective equipment normally required. When workers are facing concentrations above the exposure limit they must use appropriate certified respirators. Use NIOSH approved respiratory protection.
Hand protection Material	: Standard work gloves for frequent handling.
Eye protection	: Safety glasses with side-shields Tightly fitting safety goggles Face-shield
Skin and body protection	: Chemical resistant apron Footwear protecting against chemicals Skin should be washed after contact. Change working clothes after each workshift.
Protective measures	: Avoid contact with skin. When using do not eat, drink or smoke. Personal protective equipment comprising: suitable protective gloves, safety goggles and protective clothing The type of protective equipment must be selected according to the concentration and amount of the dangerous substance at the specific workplace.
Hygiene measures	: Do not smoke. Keep away from food and drink. Avoid contact with skin, eyes and clothing. Change working clothes after each workshift.

SECTION 9. PHYSICAL AND CHEMICAL PROPERTIES

Appearance	: liquid
Colour	: light cream
Odour	: ammoniacal

Skudo Concrete Base Coat

Version	Revision Date:	MSDS Number:	Date of last issue: -
1.0	02/10/2016	F000001879	Date of first issue: 02/10/2016

pH	: 9.5 - 10.5
VOC Content	: 1.53 g/Ltr
Melting point/range	: No data available
Boiling point/boiling range	: > 200 °F
Flash point	: No data available
Evaporation rate	: No data available
Vapour pressure	: No data available
Relative vapour density	: No data available
Density	: 958.4 kg/m3
Solubility(ies)	
Water solubility	: completely miscible
Solubility in other solvents	: not determined
Partition coefficient: n-octanol/water	: No data available

SECTION 10. STABILITY AND REACTIVITY

Reactivity	: Stable
Possibility of hazardous reactions	: Stable under recommended storage conditions.
Conditions to avoid	: Protect from frost.
Incompatible materials	: Oxidizing agents Strong acids and strong bases
Hazardous decomposition products	: Carbon dioxide (CO ₂), carbon monoxide (CO), oxides of nitrogen (NO _x), dense black smoke.

SECTION 11. TOXICOLOGICAL INFORMATION**Acute toxicity****Product:**

Acute oral toxicity	: Remarks: This information is not available.
Acute inhalation toxicity	: Remarks: This information is not available.
Acute dermal toxicity	: Remarks: This information is not available.

Skudo Concrete Base Coat



Version 1.0 Revision Date: 02/10/2016 MSDS Number: F000001879 Date of last issue: -
Date of first issue: 02/10/2016

Skin corrosion/irritation

Product:

Remarks: This information is not available.

Serious eye damage/eye irritation

Product:

Remarks: This information is not available.

Respiratory or skin sensitisation

Product:

Remarks: This information is not available.

Carcinogenicity

IARC

No component of this product present at levels greater than or equal to 0.1% is identified as probable, possible or confirmed human carcinogen by IARC.

OSHA

No component of this product present at levels greater than or equal to 0.1% is identified as a carcinogen or potential carcinogen by OSHA.

NTP

No component of this product present at levels greater than or equal to 0.1% is identified as a known or anticipated carcinogen by NTP.

SECTION 12. ECOLOGICAL INFORMATION

Ecotoxicity

Product:

Toxicity to fish : Remarks: No data available

Toxicity to daphnia and other aquatic invertebrates : Remarks: No data available

Toxicity to algae : Remarks: No data available

Persistence and degradability

No data available

Bioaccumulative potential

No data available

Mobility in soil

No data available

Skudo Concrete Base Coat



Version 1.0 Revision Date: 02/10/2016 MSDS Number: F000001879 Date of last issue: -
Date of first issue: 02/10/2016

Other adverse effects

No data available

SECTION 13. DISPOSAL CONSIDERATIONS

Disposal methods

- Waste from residues : Do not dispose of waste into sewer.
Dispose of in accordance with local regulations.
Can be landfilled or incinerated, when in compliance with local regulations.

 - Contaminated packaging : Clean container with water.
Empty containers should be taken to an approved waste handling site for recycling or disposal.
-

SECTION 14. TRANSPORT INFORMATION

International Regulation UNRTDG

Not regulated as a dangerous good

IATA-DGR

Not regulated as a dangerous good

IMDG-Code

Not regulated as a dangerous good

Transport in bulk according to Annex II of MARPOL 73/78 and the IBC Code Not applicable for product as supplied.

National Regulations 49 CFR

Not regulated as a dangerous good

49 CFR

Not regulated as a dangerous good

SECTION 15. REGULATORY INFORMATION

SARA 302 : No chemicals in this material are subject to the reporting requirements of SARA Title III, Section 302.

SARA 313 : This material does not contain any chemical components with known CAS numbers that exceed the threshold (De Minimis) reporting levels established by SARA Title III, Section 313.

California Prop 65 WARNING: This product contains a chemical known to the State of California to cause birth defects or other reproductive harm.

SAFETY DATA SHEET

Skudo Concrete Base Coat



Version 1.0 Revision Date: 02/10/2016 MSDS Number: F000001879 Date of last issue: -
 Date of first issue: 02/10/2016

methanol

67-56-1

SECTION 16. OTHER INFORMATION

Further information

NFPA:

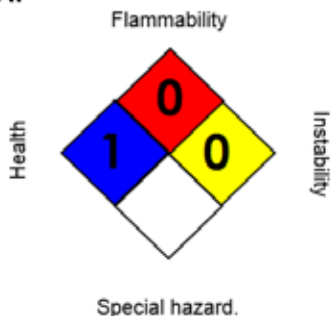

HMIS III:

HEALTH	1
FLAMMABILITY	0
PHYSICAL HAZARD	0

0 = not significant, 1 =Slight,
 2 = Moderate, 3 = High
 4 = Extreme, * = Chronic

Revision Date : 02/10/2016

The information provided in this Safety Data Sheet is correct to the best of our knowledge, information and belief at the date of its publication. The information given is designed only as a guidance for safe handling, use, processing, storage, transportation, disposal and release and is not to be considered a warranty or quality specification. The information relates only to the specific material designated and may not be valid for such material used in combination with any other materials or in any process, unless specified in the text.

US / EN



SAFETY DATA SHEET

PRODUCT NAME: HT Tack-Mat

ISSUE DATE: July 29, 2014

ISSUED BY: Skudo LLC

1. IDENTIFICATION OF THE SUBSTANCE / PREPARATION AND OF THE COMPANY / UNDERTAKING

Product name: SKUDO HT TACK MAT

Product code: 1130 TACK-MAT - HT

**Use of substance /
preparation:** Protective mat

Company name: Skudo LLC
11120 Zodiac Ln
Dallas
TX
75229
USA
Tel: 972-993-0777
Fax: 972-993-0700

2. HAZARDS IDENTIFICATION

Main hazards: No significant hazard.

3. COMPOSITION / INFORMATION ON INGREDIENTS

Contains: Polyester film with modified acrylic adhesive.

4. FIRST AID MEASURES (SYMPTOMS)

Skin contact: No symptoms.

Eye contact: No symptoms.

Ingestion: It is unlikely that this substance will be swallowed due to its physical properties.

Inhalation: No symptoms.

5. FIRE-FIGHTING MEASURES

Extinguishing media: Suitable extinguishing media for the surrounding fire should be used.

Protection of fire-fighters: Wear self-contained breathing apparatus. Wear protective clothing to prevent contact with skin and eyes.

6. ACCIDENTAL RELEASE MEASURES

Personal precautions: Refer to section 8 of SDS for personal protection details.

7. HANDLING AND STORAGE

Storage Directions: Store in a dry place.

8. EXPOSURE CONTROLS / PERSONAL PROTECTION

Respiratory protection: Respiratory protection not required.

9. PHYSICAL AND CHEMICAL PROPERTIES

State: Solid

Color: Orange

Odor: Odorless

10. STABILITY AND REACTIVITY

Stability: Stable under normal conditions.

11. TOXICOLOGICAL INFORMATION

Acute toxicity: SKUDO HT TACK MAT

ORL RAT LD50 >2000 mg/kg

Routes of exposure: Refer to section 4 of SDS for routes of exposure and corresponding symptoms.

12. ECOLOGICAL INFORMATION

Persistence and degradability: Biodegradable in part only.

13. DISPOSAL CONSIDERATIONS

Disposal operations: D10 Incineration on land. Skudo Tack-Mat is a non-hazardous waste in its fully treated form. It may be disposed of with other non-hazardous waste streams, with the prior agreement of your waste contractor.

Disposal of packaging: Dispose of as normal industrial waste.

NB: The user's attention is drawn to the possible existence of regional or national regulations regarding disposal.

14. TRANSPORT INFORMATION

Classification: Not defined as Dangerous Goods by DOT for road or rail. Class 65.

15. REGULATORY INFORMATION

Hazard symbols: No significant hazard.

Note: The regulatory information given above only indicates the principal regulations specifically applicable to the product described in the safety data sheet. The user's attention is drawn to the possible existence of additional provisions which complete these regulations. Refer to all applicable national, international and local regulations or provisions.

16. OTHER INFORMATION

Other information: This Material safety Data Sheet has been prepared in compliance with European Regulation (EC) No. 1907/2006 (REACH)

Legal disclaimer: The above information is believed to be correct but does not purport to be all inclusive and shall be used only as a guide. This company shall not be held liable for any damage resulting from handling or from contact with the above product.



SAFETY DATA SHEET

PRODUCT NAME: LT Tack-Mat, Counter Mat, Edge Protect

ISSUE DATE: June 23, 2016

ISSUED BY: Skudo LLC

1. IDENTIFICATION OF THE SUBSTANCE / PREPARATION AND OF THE COMPANY / UNDERTAKING

Product name: SKUDO LT TACK MAT, SKUDO COUNTER MAT, SKUDO EDGE PROTECT

Product code: TM-LT-3.3-165, TM-LT-2.25-82-COUNTER, TM-EP-12i-82, TM-EP-8i-50

**Use of substance /
preparation:** Protective mat

Company name: Skudo LLC
11120 Zodiac Ln
Dallas
TX
75229
USA
Tel: 972-993-0777
Fax: 972-993-0700

2. HAZARDS IDENTIFICATION

Main hazards: No significant hazard.

3. COMPOSITION / INFORMATION ON INGREDIENTS

Contains: Polyester film with modified acrylic adhesive.

4. FIRST AID MEASURES

Skin contact: No symptoms.

Eye contact: No symptoms.

Ingestion: It is unlikely that this substance will be swallowed due to its physical properties.

Inhalation: No symptoms.

5. FIRE-FIGHTING MEASURES

Extinguishing media: Suitable extinguishing media for the surrounding fire should be used.

Protection of fire-fighters: Wear self-contained breathing apparatus. Wear protective clothing to prevent contact with skin and eyes.

6. ACCIDENTAL RELEASE MEASURES

Personal precautions: Refer to section 8 of SDS for personal protection details.

7. HANDLING AND STORAGE

Storage Directions: Store in a dry place.

8. EXPOSURE CONTROLS / PERSONAL PROTECTION

Respiratory protection: Respiratory protection not required.

9. PHYSICAL AND CHEMICAL PROPERTIES

State: Solid

Color: Grey

Odor: Odorless

10. STABILITY AND REACTIVITY

Stability: Stable under normal conditions.

11. TOXICOLOGICAL INFORMATION

Acute toxicity: SKUDO LT TACK MAT

ORL RAT LD50 >2000 mg/kg

Routes of exposure: Refer to section 4 of SDS for routes of exposure and corresponding symptoms.

12. ECOLOGICAL INFORMATION

Persistence and degradability: Biodegradable in part only.

13. DISPOSAL CONSIDERATIONS

Disposal operations: D10 Incineration on land. Skudo Tack-Mat is a non-hazardous waste in its fully treated form. It may be disposed of with other non-hazardous waste streams, with the prior agreement of your waste contractor.

Disposal of packaging: Dispose of as normal industrial waste.

NB: The user's attention is drawn to the possible existence of regional or national regulations regarding disposal.

14. TRANSPORT INFORMATION

Classification: Not defined as Dangerous Goods by DOT for road or rail. Class 65.

15. REGULATORY INFORMATION

Hazard symbols: No significant hazard.

Note: The regulatory information given above only indicates the principal regulations specifically applicable to the product described in the safety data sheet. The user's attention is drawn to the possible existence of additional provisions which complete these regulations. Refer to all applicable national, international and local regulations or provisions.

16. OTHER INFORMATION

Other information: This Material safety Data Sheet has been prepared in compliance with European Regulation (EC) No. 1907/2006 (REACH)

Legal disclaimer: The above information is believed to be correct but does not purport to be all inclusive and shall be used only as a guide. This company shall not be held liable for any damage resulting from handling or from contact with the above product.



SAFETY DATA SHEET

PRODUCT NAME: High Impact (HI) Construction Tack-Mat

ISSUE DATE: July 29, 2016

ISSUED BY: Skudo LLC

1. IDENTIFICATION OF THE SUBSTANCE / PREPARATION AND OF THE COMPANY / UNDERTAKING

Product name: SKUDO HIGH IMPACT (HI) CONSTRUCTION TACK MAT

Product code: TM-HI-3.3-82-IMPACT

**Use of substance /
preparation:** Protective mat

Company name: Skudo LLC
11120 Zodiac Ln.
Dallas
TX
75229
USA
Tel: 972-993-0777
Fax: 972-993-0700

2. HAZARDS IDENTIFICATION

Main hazards: No significant hazard.

3. COMPOSITION / INFORMATION ON INGREDIENTS

Contains: Polyester film with modified acrylic adhesive.

4. FIRST AID MEASURES

Skin contact: No symptoms.

Eye contact: No symptoms.

Ingestion: It is unlikely that this substance will be swallowed due to its physical properties.

Inhalation: No symptoms.

5. FIRE-FIGHTING MEASURES

Extinguishing media: Suitable extinguishing media for the surrounding fire should be used.

Protection of fire-fighters: Wear self-contained breathing apparatus. Wear protective clothing to prevent contact with skin and eyes.

6. ACCIDENTAL RELEASE MEASURES

Personal precautions: Refer to section 8 of SDS for personal protection details.

7. HANDLING AND STORAGE

Storage Instructions: Store in a dry place.

8. EXPOSURE CONTROLS / PERSONAL PROTECTION

Respiratory protection: Respiratory protection not required.

9. PHYSICAL AND CHEMICAL PROPERTIES

State: Solid

Color: Dark Grey

Odor: Odorless

10. STABILITY AND REACTIVITY

Stability: Stable under normal conditions.

11. TOXICOLOGICAL INFORMATION

Acute toxicity: SKUDO HI TACK MAT
ORL RAT LD50 >2000 mg/kg

Routes of exposure: Refer to section 4 of SDS for routes of exposure and corresponding symptoms.

12. ECOLOGICAL INFORMATION

Persistence and degradability: Biodegradable in part only.

13. DISPOSAL CONSIDERATIONS

Disposal operations: D10 Incineration on land. Skudo Tack-Mat is a non-hazardous waste in its fully treated form. It may be disposed of with other non-hazardous waste streams, with the prior agreement of your waste contractor.

Disposal of packaging: Dispose of as normal industrial waste.

NB: The user's attention is drawn to the possible existence of regional or national regulations regarding disposal.

14. TRANSPORT INFORMATION

Classification: Not defined as Dangerous Goods by DOT for road, air, rail or sea.

15. REGULATORY INFORMATION

Hazard symbols: No significant hazard.

Note: The regulatory information given above only indicates the principal regulations specifically applicable to the product described in the safety data sheet. The user's attention is drawn to the possible existence of additional provisions which complete these regulations. Refer to all applicable national, international and local regulations or provisions.

16. OTHER INFORMATION

Other information: This Material safety Data Sheet has been prepared in compliance with European Regulation (EC) No. 1907/2006 (REACH)

Legal disclaimer: The above information is believed to be correct but does not purport to be all inclusive and shall be used only as a guide. This company shall not be held liable for any damage resulting from handling or from contact with the above product.

Skudo All-Terrain Mat

Page: 1 of 5

Compilation Date: 6/15/18

Revision No: 0

Skudo All-Terrain Mat**Safety Data Sheet (SDS)****SECTION 1: PRODUCT AND COMPANY IDENTIFICATION**

PRODUCT NAME: Skudo All-Terrain Mat
MANUFACTURER: Skudo LLC
ADDRESS: 11120 Zodiac Ln
 Dallas, TX 75229

EMERGENCY PHONE:	1-888-758-3611 or (972) 993-0777
-------------------------	----------------------------------

Issue Date: 6/15/2018
Supersedes Date: Initial Issue

Product Use: Specific Use: Floor matting for outdoor and recessed well areas, suitable for even the heaviest traffic conditions

SECTION 2: HAZARDS IDENTIFICATION**2.1 EMERGENCY OVERVIEW****Immediate health, physical, and environmental hazards:**

This product, when used under reasonable conditions and in accordance with the Skudo directions for use, should not present a health hazard. However, use or processing of the product in a manner not in accordance with the product's directions for use may affect the performance of the product and may present potential health and safety hazards.

2.2 POTENTIAL HEALTH EFFECTS

Eye Contact: No health effects are expected.

Skin Contact: No health effects are expected.

Inhalation: No health effects are expected.

Ingestion: No health effects are expected.

SECTION 3: COMPOSITION/INFORMATION ON INGREDIENTS

<u>Ingredient</u>	<u>C.A.S. No</u>	<u>% by Wt</u>
POLY(VINYL CHLORIDE)	9002-86-2	5 - 45
DI-C9-11-BRANCHED AND LINEAR ALKYL PHTHALATES	68515-43-5	5 - 35
TALC	14807-96-6	0.5 - 10
EPOXIDIZED SOYBEAN OIL	8013-07-8	0.5 - 10
LIMESTONE	1317-65-3	< 5
LEAD CHROMATE PIGMENT	Trade Secret	< 5



Skudo All-Terrain Mat

Page: 2 of 5

Compilation Date: 6/15/18

Revision No: 0

MISC. ADDITIVES	Trade Secret	< 5
LEAD	7439-92-1	< 2
VINYL CHLORIDE-VINYL ACETATE POLYMER	9003-22-9	0.5 - 3
DI-C8-10-BRANCHED ALKYL PHTHALATE, C9 RICH	68515-48-0	0.5 - 3

SECTION 4: FIRST AID MEASURES

4.1 FIRST AID PROCEDURES

The following first aid recommendations are based on an assumption that appropriate personal and industrial hygiene practices are followed.

Eye Contact:	No need for first aid is anticipated.
Skin Contact:	No need for first aid is anticipated.
Inhalation:	No need for first aid is anticipated.
If Swallowed:	No need for first aid is anticipated.

SECTION 5: FIRE FIGHTING MEASURES

5.1 FLAMMABLE PROPERTIES

OSHA Flammability Classification: Not Applicable

5.2 EXTINGUISHING MEDIA

Material will not burn. Use fire extinguishers with class B extinguishing agents (e.g., dry chemical, carbon dioxide).

5.3 PROTECTION OF FIRE FIGHTERS

Special Fire Fighting Procedures:	Wear full protective equipment (Bunker Gear) and a self-contained breathing apparatus (SCBA).
Unusual Fire and Explosion Hazards:	No unusual fire or explosion hazards are anticipated.

SECTION 6: ACCIDENTAL RELEASE MEASURES

Accidental Release Measures: Not applicable.

SECTION 7: HANDLING AND STORAGE

7.1 HANDLING

This product is considered to be an article which does not release or otherwise result in exposure to a hazardous chemical under normal use conditions.

Skudo All-Terrain Mat



7.2 STORAGE

Store under normal warehouse conditions.

SECTION 8: EXPOSURE CONTROLS/PERSONAL PROTECTION

8.1 ENGINEERING CONTROLS

Not applicable.

8.2 PERSONAL PROTECTIVE EQUIPMENT (PPE)

8.2.1 Eye/Face Protection

Not applicable.

8.2.2 Skin Protection

Gloves are not required.

8.2.3 Respiratory Protection

Under normal use conditions, airborne exposures are not expected to be significant enough to require respiratory protection.

8.2.4 Prevention of Swallowing

Not applicable.

8.3 EXPOSURE GUIDELINES

None Established

SECTION 9: PHYSICAL AND CHEMICAL PROPERTIES

Specific Physical Form:	Non-Woven Material
Odor, Color, Grade:	Orange unbacked, vinyl z-web
General Physical Form:	Solid

Specific Gravity	<i>Not Applicable</i>
-------------------------	-----------------------

SECTION 10: STABILITY AND REACTIVITY

Stability:	Stable.
Materials and Conditions to Avoid:	None known
Hazardous Polymerization:	Hazardous polymerization will not occur.
Hazardous Decomposition:	Under recommended usage conditions, hazardous decomposition products are not expected. Hazardous decomposition products may occur as a result of oxidation, heating, or reaction with another material.

Skudo All-Terrain Mat

Page: 4 of 5

Compilation Date: 6/15/18

Revision No: 0

SECTION 11: TOXICOLOGICAL INFORMATION

Please contact the address listed on the first page of the SDS for Toxicological Information on this material and/or its components.

SECTION 12: ECOLOGICAL INFORMATION**ECOTOXICOLOGICAL INFORMATION**

Not applicable.

CHEMICAL FATE INFORMATION

Not applicable.

SECTION 13: DISPOSAL CONSIDERATIONS

Waste Disposal Method: Dispose of waste product in a permitted hazardous waste facility.

EPA Hazardous Waste Number (RCRA): D005 (Barium), D007 (Chromium), D008 (Lead)

Since regulations vary, consult applicable regulations or authorities before disposal.

SECTION 14: TRANSPORT INFORMATION

Please contact the emergency numbers listed on the first page of the SDS for Transportation Information for this material.

SECTION 15: REGULATORY INFORMATION**US FEDERAL REGULATIONS**

Contact Skudo for more information.

311/312 Hazard Categories:

Fire Hazard - No Pressure Hazard - No Reactivity Hazard - No Immediate Hazard - No
Delayed Hazard - No

Section 313 Toxic Chemicals subject to the reporting requirements of that section and 40 CFR part 372 (EPCRA):

<u>Ingredient</u>	<u>C.A.S. No</u>	<u>% by Wt</u>
LEAD	7439-92-1	< 2
LEAD (LEAD COMPOUNDS)	7439-92-1	< 2

STATE REGULATIONS

Contact Skudo for more information.

CHEMICAL INVENTORIES

Skudo All-Terrain Mat

Page: 5 of 5

Compilation Date: 6/15/18

Revision No: 0

This product is an article as defined by TSCA regulations, and is exempt from TSCA Inventory listing requirements.

Contact Skudo for more information.

INTERNATIONAL REGULATIONS

Contact Skudo for more information.

This SDS has been prepared to meet the U.S. OSHA Hazard Communication Standard, 29 CFR 1910.1200.

SECTION 16: OTHER INFORMATION**NFPA Hazard Classification**

Health: 0 Flammability: 0 Reactivity: 0 Special Hazards: None

National Fire Protection Association (NFPA) hazard ratings are designed for use by emergency response personnel to address the hazards that are presented by short-term, acute exposure to a material under conditions of fire, spill, or similar emergencies. Hazard ratings are primarily based on the inherent physical and toxic properties of the material but also include the toxic properties of combustion or decomposition products that are known to be generated in significant quantities.

HMIS Hazard Classification

Health: 0 Flammability: 0 Reactivity: 0 Protection: A

Hazardous Material Identification System (HMIS®) hazard ratings are designed to inform employees of chemical hazards in the workplace. These ratings are based on the inherent properties of the material under expected conditions of normal use and are not intended for use in emergency situations. HMIS® ratings are to be used with a fully implemented HMIS® program. HMIS® is a registered mark of the National Paint and Coatings Association (NPCA).

No revision information is available.

DISCLAIMER: The information in this Safety Data Sheet (SDS) is believed to be correct as of the date issued. SKUDO LLC MAKES NO WARRANTIES, EXPRESSED OR IMPLIED, INCLUDING, BUT NOT LIMITED TO, ANY IMPLIED WARRANTY OF MERCHANTABILITY OR FITNESS FOR A PARTICULAR PURPOSE OR COURSE OF PERFORMANCE OR USAGE OF TRADE. User is responsible for determining whether the Skudo product is fit for a particular purpose and suitable for user's method of use or application. Given the variety of factors that can affect the use and application of a Skudo product, some of which are uniquely within the user's knowledge and control, it is essential that the user evaluate the Skudo product to determine whether it is fit for a particular purpose and suitable for user's method of use or application.

Skudo provides information in electronic form as a service to its customers. Due to the remote possibility that electronic transfer may have resulted in errors, omissions or alterations in this information, Skudo makes no representations as to its completeness or accuracy. In addition, information obtained from a database may not be as current as the information in the SDS available directly from Skudo.

Skudo SDSs are available at www.skudousa.com



SAFETY DATA SHEET
according to 1907/2006/EC, Article 31

Skudo Glass Advanced

Revision 0
Revision date 2013-01-16

Page 1

SECTION 1: Identification of the substance/mixture and of the company/undertaking

1.1. Product identifier

Product name	Skudo Glass Advanced
--------------	----------------------

1.3. Details of the supplier of the safety data sheet

Company	Skudo LLC
Address	11120 Zodiac Ln DALLAS TEXAS 75229 USA
Telephone	888-758-3611
Email	info@skudousa.com

1.4. Emergency telephone number

Emergency telephone number	888-758-3611 9.00 am - 5.00 pm
----------------------------	-----------------------------------

SECTION 2: Hazards identification

2.1. Classification of the substance or mixture

Main hazards	No Significant Hazard
--------------	-----------------------

SECTION 3: Composition/information on ingredients

3.2. Mixtures

67/548/EEC / 1999/45/EC

Chemical Name	Index No.	CAS No.	EC No.	REACH Registration Number	Conc. (%w/w)	Classification
Di-isononyl phthalate		28553-12-0	249-079-5		10 - 20%	
2-(2-Butoxyethoxy)ethanol	603-096-00-8	112-34-5	203-961-6		1 - 10% Xi; R36	
Hydroxyphenyl benzotriazole derivatives			400-830-7		0.5 - 1% Xi; R43 N; R51/53	

SECTION 4: First aid measures

4.1. Description of first aid measures

Inhalation	May cause irritation to mucous membranes. Move the exposed person to fresh air. Seek medical attention if irritation or symptoms persist.
Eye contact	Contact lenses should be removed. Rinse immediately with plenty of water for 15 minutes holding the eyelids open. Seek medical attention.
Skin contact	Wash off immediately with plenty of soap and water. Remove contaminated clothing. Seek medical attention if irritation or symptoms persist. May cause irritation to skin.
Ingestion	DO NOT INDUCE VOMITING. Seek medical attention.

SECTION 5: Firefighting measures

5.1. Extinguishing media

	Carbon dioxide (CO2). Foam. Water spray.
--	--

5.2. Special hazards arising from the substance or mixture

	Burning produces irritating, toxic and obnoxious fumes.
--	---

5.3. Advice for firefighters

	Wear suitable respiratory equipment when necessary. In case of fire and/or explosion do not breathe fumes. Protective equipment.
--	--

SECTION 6: Accidental release measures

6.1. Personal precautions, protective equipment and emergency procedures

	Approved safety goggles. Do not breathe gas/fumes/vapour/spray. During fumigation/spraying wear suitable respiratory equipment. Ensure adequate ventilation of the working area. Protective clothing.
--	---

6.2. Environmental precautions

	Do not allow product to enter drains. Prevent further spillage if safe.
--	---

6.3. Methods and material for containment and cleaning up

	Absorb with inert, absorbent material. Transfer to suitable, labelled containers for disposal. Clean spillage area thoroughly with plenty of water.
--	---

SECTION 7: Handling and storage

7.1. Precautions for safe handling

	Adopt best Manual Handling considerations when handling, carrying and dispensing. Do not breathe gas/fumes/vapour/spray. During fumigation/spraying wear suitable respiratory equipment. Ensure adequate ventilation of the working area. When using do not eat or drink.
--	--

7.2. Conditions for safe storage, including any incompatibilities

	Do NOT allow to freeze. Do NOT mix with any other product. Keep containers tightly closed. Keep in a cool, dry, well ventilated area. Store in correctly labelled containers.
--	---

SECTION 8: Exposure controls/personal protection

8.1. Control parameters

8.1.1. Exposure Limit Values

2-(2-Butoxyethoxy)ethanol	WEL 8-hr limit ppm: 10	WEL 8-hr limit mg/m3: 67.5
	WEL 15 min limit ppm: 15	WEL 15 min limit mg/m3: 101.2
Di-isononyl phthalate	WEL 8-hr limit ppm: -	WEL 8-hr limit mg/m3: 5
	WEL 15 min limit ppm: -	WEL 15 min limit mg/m3: -

8.2. Exposure controls

8.2.1. Appropriate engineering controls	Ensure adequate ventilation of the working area.
8.2.2. Individual protection measures	Wear chemical protective clothing.
Eye / face protection	Approved safety goggles. Avoid contact with eyes.
Skin protection -	
Handprotection	Chemical resistant gloves (PVC).
Respiratory protection	Wear:. Self-contained breathing apparatus.

SECTION 9: Physical and chemical properties

9.1. Information on basic physical and chemical properties

State	Aqueous solution
Color	Various
Odor	Slight
pH	7 - 8
Boiling point	100 ° C
Solubility	Miscible in water

9.2. Other information

Specific gravity	1.09 80
VOC (Volatile organic compounds)	g/l

SECTION 10: Stability and reactivity

10.2. Chemical stability

	Stable under normal conditions.
--	---------------------------------

SECTION 11: Toxicological information

11.1. Information on toxicological effects

Skin corrosion/irritation	Irritating to eyes and skin.
---------------------------	------------------------------

11.1.4. Toxicological Information

	No data available
--	-------------------

SECTION 12: Ecological information

12.1. Toxicity

	R51/53 - Toxic to aquatic organisms, may cause long-term adverse effects in the aquatic environment.
--	--

SECTION 13: Disposal considerations

General information

	Dispose of in compliance with all local and national regulations.
--	---

SECTION 14: Transport information

Classification

	Not defined as Dangerous Goods by DOT for road, air, rail, or sea. Class 60.
--	--

SECTION 15: Regulatory information

Labelling

Risk phrases Safety phrases	The product is classified in accordance with 67/548/EEC.
	No Significant Hazard.
	S23 - Do not breathe gas/fumes/vapor/spray.
	S29 - Do not empty into drains. S42 - During fumigation/spraying wear suitable respiratory equipment. S51 - Use only in well-ventilated areas.

SECTION 16: Other information

Other information

Text of risk phrases in Section 3	R36 - Irritating to eyes. R43 - May cause sensitization by skin contact.
-----------------------------------	---

Other information

Maximum content of VOC	80 g/l.
------------------------	---------

Further information

	<p>The information supplied in this Safety Data Sheet is designed only as guidance for the safe use, storage and handling of the product. This information is correct to the best of our knowledge and belief at the date of publication however no guarantee is made to its accuracy. This information relates only to the specific material designated and may not be valid for such material used in combination with any other materials or in any other process.</p>
--	---



Safety Data Sheet

Product: SkudoBoard

Issue Date: June 18, 2018

1. IDENTIFICATION

1.1	Product Name:	SkudoBoard
1.2	Chemical Classification	Flame Retardant PP Board
1.3	Product Operation Suggestions and Restrictions:	Construction
1.4	Company Introduction	
	Manufacturer/Supplier Name:	Skudo LLC
	Address:	11120 Zodiac Ln Dallas, TX 75229 USA
	Tel:	+1 (972) 993-0777
	Fax:	+1 (972) 993-0700
	E-mail	info@skudousa.com
	Emergency Tel:	+1 (972) 993-0777
1.5	First Issue Date	June 18, 2018

2. HAZARDS IDENTIFICATION

2.1	Color:	Black or Grey.
	Physical State:	Board or Panel.
	Odor:	Inodorous or slight odor.
2.2	Hazard Classification:	No harm.
2.3	Signs and Precautionary Statements	
	Graphic Symbol:	None.
	Signal Word:	None.
2.4	Cardinal Symptom after Contact	
	Eye Protection:	Use safety glasses. Safety glasses should be consistent with Directive 89/686/EEC Category 2. If there is a potential for exposure to board which could cause eye discomfort, wear chemical goggles. Chemical goggles should be consistent with EN 166 or equivalent. If exposure causes eye discomfort, use a full-face respirator.
	Skin Protection:	No precautions other than clean body-covering clothing should be needed.
	Hand Protection:	Chemical protective gloves should not be needed when handling this material. Consistent with general hygienic practice for any material, skin contact should be minimized. Use gloves with insulation for thermal protection, when needed.
	Respiratory Protection:	Use an approved air-purifying respirator when vapors are generated at increased temperatures or when dust or mist is present. Use the following CE approved air-purifying respirator: When dust/mist are present use a Particulate filter, type P2. When combinations of vapors, acids, or dusts/mists are present use an organic vapor cartridge with a particulate pre-filter, type AP2.
	Ingestion:	Low toxicity. It may cause choking if swallowed.
2.5	Emergency Measures:	Avoid contact with eyes.
2.6	Other Hazards:	Unknown

3. COMPOSITION INFORMATION ON INGREDIENTS

3.1	Chemical Classification:	Compound Mixture	
3.2	Risk Composition:	Flame Retardant PP Board	
	<u>Chemical Name</u>	<u>CAS#</u>	<u>% (w/w)</u>
	Polypropylene	9003-07-0	55%-80%
	Flame Retardant		1%-10%
	Filler and assistant		1%-25%

4. FIRST AID MEASURES

4.1	First Aid Measures	
	Eye Contact:	Flush eye thoroughly with water for several minutes. Remove contact lenses after the initial 1-2 minutes and continue flushing for several additional minutes. If effects occur, consult a doctor, preferably an ophthalmologist.
	Skin Contact:	If molten material meets skin, do not apply ice but cool under ice water or running stream of water. Do not attempt to remove the material from the skin. Removal may result in severe tissue damage. Seek medical attention immediately.
	Inhalation:	Move person to fresh air; if effects occur, consult a doctor.
	Ingestion:	If swallowed, seek medical treatment. May cause gastrointestinal blockage. Do not induce vomiting unless directed to do so by medical personnel.
4.2	Notes to Doctor:	If burn is present, treat as any thermal burn, after decontamination. No specific antidote. Treatment of exposure should be directed at the control of symptoms and the clinical condition of the patient.

5. FIRE-FIGHTING MEASURES

5.1	Suitable Extinguishing Media:	Water fog or fine spray. Dry powder fire extinguishers, carbon dioxide fire extinguishers, foam.
5.2	Prohibited Fire Extinguishing Agent:	Unknown.
5.3	Special Drainage:	None.
5.4	Special Fire Extinguishing Procedure:	Evacuate personnel from fire. Isolate of fire and prohibit unwanted people into fire zone. Soak the burning material thoroughly with water to cool and

prevent reignition. If the material is molten, do not apply direct water stream. Use fine water spray or foam. Cool surroundings with water to cool fire zone. Extinguish small fire with hand-held dry power fire extinguisher or carbon dioxide extinguisher.

Ingestion:

If swallowed, seek medical treatment. May cause gastrointestinal blockage. Do not induce vomiting unless directed to do so by medical personnel.

5.5 Special Protective Equipment for Firefighters:

Wear positive-pressure self-contained breathing apparatus (SCBA) and protective clothing (includes fire helmet, coat, trousers, boots and gloves). If protective equipment is not available or not used, fight fire from a protected location or safe distance.

6. ACCIDENTAL RELEASE MEASURES

6.1 Personal Precautions:

Spilled material may cause a slipping hazard. Use appropriate safety equipment.

6.2 Environmental Precautions:

Prevent from entering soil, ditches, sewers, waterways and / or groundwater.

6.3 Elimination Method:

Contain spilled material if possible. Sweep up. Collect in suitable and properly labeled container.

7. HANDLING AND STORAGE

7.1 Handling Precautions:

Workers should be protected from the possibility of contact with molten resin. Do not get molten material in eyes, on skin or clothing. Pneumatic conveying and other mechanical handling operations can generate combustible dust. To reduce the potential for dust explosions, electrically bond and ground equipment and do not permit dust to accumulate. Dust can be ignited by static.

7.2 Storage Precautions:

Store in accordance with good manufacturing practices.

7.3 Unsuitable Packing Materials:

Unknown.

8. EXPOSURE CONTROLS / PERSONAL PROTECTION

8.1 Industrial Hygiene Standards

Exposure Limit:

Unknown

8.2 Engineering Controls

Good general ventilation should be sufficient for most conditions.

Ventilation Local exhaust ventilation may be necessary for some operations.

8.3 Personal Protection

Respiratory Protection: Use an approved air-purifying respirator when vapors are generated at increased temperatures or when dust/mist is present. The following should be effective types of air-purifying respirators: When dust/mist are present use a filter. When combinations of vapors, acids, or dusts/mists are present use an organic vapor cartridge with a particulate pre-filter.

Eye Protection: Use safety glasses. If there is a potential for exposure to particles which could cause eye discomfort, wear chemical goggles. If exposure causes eye discomfort, use a full-face respirator.

Hand Protection: Use gloves to protect from chemical injury. Selection of gloves will depend on the task. Use gloves with insulation for thermal.

Skin and Body Protection: No precautions other than clean body-covering clothing should be needed.

9. PHYSICAL AND CHEMICAL PROPERTIES

9.1	Physical State:	Board or Panel
9.2	Color:	Black or Grey
9.3	Odor:	Inodorous or slight odor
9.4	pH	Not applicable
9.5	Melting Point:	329-329°F (165-200°C).
9.6	Boiling Point:	Not applicable
9.7	Flash Point:	Not tested
9.8	Blast Limit in Air	
	Upper	Not tested.
	Lower:	Not tested.
9.9	Vapor Density (25°C):	Not applicable.
9.10	Vapor Pressure air=1):	Not applicable.
9.11	Density:	0.9-1.1g/cm ³
9.12	Solubility:	Negligible.

9.13	Distribution Coefficient (N-octanol/Water):	Not tested.
9.14	Autoignition Temperature:	Not tested.
9.15	Decompose Temperature:	Not tested.
9.16	Odor Threshold:	Not tested.
9.17	Evaporation Rate:	Not applicable.
9.18	Flammability (Solid, Gas):	Not applicable.

10. STABILITY AND REACTIVITY

10.1	Stability:	Stable.
10.2	Conditions to Avoid:	Products can decompose at elevated temperature.
10.3	Incompatible Materials:	Unknown.
10.4	Hazardous Polymerization:	Will not occur.
10.5	Hazardous Decomposition:	Decomposition products depend upon temperature, air supply and the presence of other materials. Processing may cause the releases of irritant smoke and other decomposition. When temperature exceeds the melting point, this product may release polymer fragments. Decomposition products could include and are not limited to: aldehydes, alcohols, organic acids and some other marginal hydrocarbons.

11. TOXICOLOGICAL INFORMATION

11.1	Exposure Ways:	Inhalation, skin contact and accidental ingestion.
11.2	Effects of Over Contact:	No notable harms under normal handling.
11.3	Acute Toxicity:	
	Eye Contact:	Direct contact may cause eye irritation experienced as mild discomfort and redness.
	Skin Absorption:	Estimated LD50, rabbit > 2000 mg/kg. No serious effects for transitory contact.
	Ingestion:	Estimated LD50, rat > 5000 mg/kg. Very low ingestion hazards under normal handling.
	Inhalation:	Estimated LC50, rat > 50 mg/1(4h, dusts/mist). No serious effects for transitory contact.
11.4	Chronic Toxicity	

Skin:	Repeated or long-time contact may cause skin irritation and dermatitis.
Ingestion:	Repeated or massive ingestion may cause physical harm.
Inhalation:	Not applicable.
11.5 Repeated Dose Toxicity:	Additives are encapsulated in the product and are not expected to be released under normal processing conditions or foreseeable emergency.
11.6 Chronic Toxicity and Carcinogenicity:	Not applicable.
11.7 Growth Toxicity:	Not applicable.
11.8 Procreation Toxicity:	Not applicable.
11.9 Inheritance Toxicity:	Not applicable.

12. ECOLOGICAL INFORMATION

12.1 Ecotoxicity:	Not expected to be acutely toxic, but may cause adverse effects by physical/mechanical means.
12.2 Resistance and Degradability:	This water-insoluble polymeric solid is expected to be inert in the environment.
12.3 Migration in Soil:	It will remain in the soil in the terrestrial environment. And it will sink into the aquatic environment.

13. DISPOSAL CONSIDERATIONS

13.1 Product Waste Disposal Ways:	Disposal according to local regulatory.
13.2 Packing Waste Disposal Ways:	Disposal according to local regulatory.

14. TRANSPORT INFORMATION

14.1 Road and Rail Transport:	Not regulated.
14.2 Sea Transportation (IMDG):	Not regulated by IMDG codes.
14.3 Air Transportation (IATA):	Not regulated by IATA.
14.4 Specific Operational Requirements:	None.

15. REGULATORY INFORMATION

15.1	Applicable Regulations:	Regulations for the Safe Use of Chemicals in Workplace [(1996) 423#, sent by Department of Labor] Public Summons for General Rules of Chemicals Classification and Hazard [GB 13690-2009]
15.2	Chemical Storage	
	TSCA:	All components of this product are on the TSCA Inventory or are exempt from TSCA Inventory requirements.
	AICS:	All substances contained in this product are listed or are exempt from requirements.
	DSL:	All substances contained in this product are listed on DSL Inventory or are exempt from DSL Inventory requirements.
	IECSC:	All substances contained in this product are listed or are exempt from requirements.
	EINECS:	All substances contained in this product are listed or are exempt from requirements.
	KECL:	All substances contained in this product are listed or are exempt from requirements.
	PICCS:	All substances contained in this product are listed or are exempt from requirements.
	HSNO:	All substances contained in this product are listed or are exempt from requirements.
	ENCS/ISHL:	All substances contained in this product are listed or are exempt from requirements.

16. OTHER INFORMATION

The product safety instructions in this safety data sheet are according to our existing knowledge and experience. This sheet does not describe the product components and specifications. Any public and/or for specific purpose product characteristics should not be removed from this data sheet. All users have responsibility and obligation to ensure the intellectual property rights of products and to abide the relevant laws and regulations.

{ Tab Here ----->
“TESTING”]

TEST: ASTM E648

Standard Test Method for Critical Radiant Flux of Floor-Covering Systems Using a Radiant Heat Energy Source

SCOPE/PURPOSE OF TEST

To measure the ability of a flooring material categorized as “interior floor finish” to limit the progression of a fire through a corridor. The test attempts to simulate a situation where the flooring material in the corridor would be subjected to igniting flames and radiant heat emanating from a fire in a room adjacent to the corridor. The test was designed to achieve a more realistic rating for flooring materials which had been previously tested by the ASTM E84 Tunnel Test, which tests all materials in the ceiling of the test chamber.

BRIEF DESCRIPTION OF TEST

A test specimen, 9” x 41”, is placed on the floor of the test chamber. A gas-fired radiant heater is situated above the test specimen. The exposed specimen face, 8” x 40”, experiences a heat flux of about 1.1 watts/cm² at the point closest to the radiant heater. The heat experienced by the specimen declines until it reaches a low of about 0.1 W/cm² at the far end of the specimen.

A multi-flamelet burner sits 2” above the near end of the test specimen. After a 5 minute period, the multi-flamelet burner is placed in contact with the near end of the test specimen. If flaming is indicated on the specimen, the test is continued to the point where the flaming or surface burning extinguishes. This point of extinguishment is referred to as the “critical radiant flux at flameout”. The less distance the specimen burns, the higher the “critical radiant flux” value. The higher the value, the better the classification of the tested material.

CLASSIFICATION SYSTEM

Values which are usually cited by model building codes written by NFPA (National Fire Protection Agency) and ICC (International Code Council) for interior floor finish materials:

Class	Minimum Critical Radiant Flux at Flameout
1	0.45 W/cm ²
2	0.22 W/cm ²

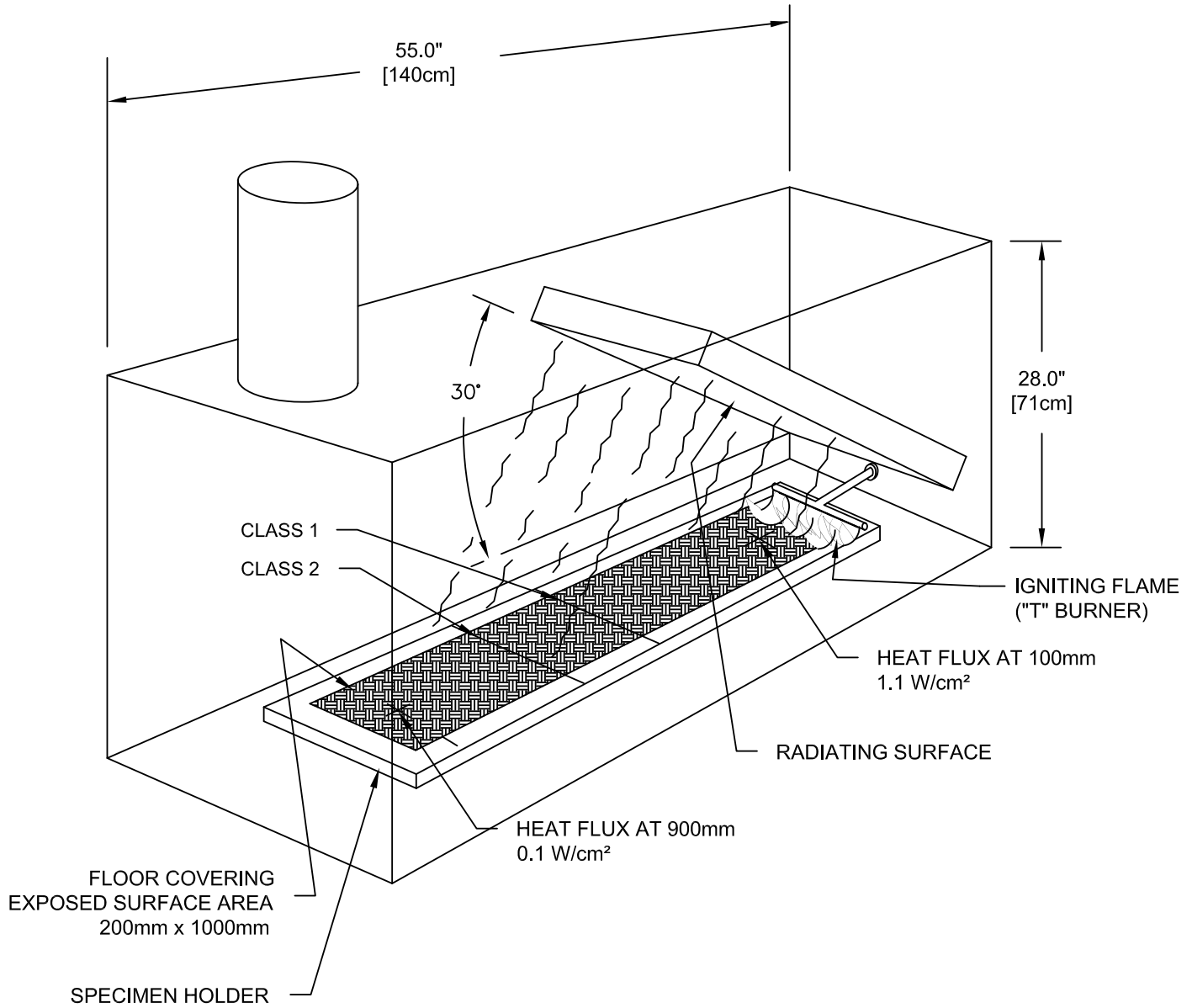

ASTM E648

**Standard Test Method for Critical Radiant Flux of
Floor-Covering Systems Using a Radiant Heat Energy Source**

Sketches of Tests: ASTM E648
Building Codes: ASTM E648
Rail Cars: ASTM E648
Buses/Vans: ASTM E648
(CAD) TM: ASTM_E648



Received:04/28/2017	Completed:05/09/2017	Letter: M	JB	P.O.#:	Test Report #:	3-18549-0-
Client's Identification	Lot No.: Temporary Surface Protection. Date of Mfg.: April 2017. Style: Skudo HT Mat. Composition: 100% Polyester Non-Woven Textile with High Traffic Coating. (see continuation)					
Tested For: Brendon Smith	Skudo USA 2330 Alberta Drive, # 200 Dallas, TX 75229			Key Test: ASTM E 648 (BLDG) WIT	795	
				Tel: 1-(972)-993-0777	Ext:	
				Fax: 1-()- -		

CLIENT'S IDENTIFICATION (continuation):

[Release paper removed prior to testing.]

ASTM E 648: LE 2015; V 09/15 PC: 48H or 96H NTR 04/12 /dl SM/mg
 NFPA 101: LE 2015; V 04/15
 NFPA 5000: LE 2015; V 04/15
 IBC: LE 2015; V 03/15

APPROXIMATE THICKNESS OF MATERIAL (as measured by Govmark): 0.038"

BRIEF DESCRIPTION OF TEST: The test specimen is placed on the floor of the test chamber. A gas-fired radiant heater is situated above the test specimen. A multi-flamelet burner is positioned above the specimen at the test starting point. After a 5 minute preheat period, the multi-flamelet burner is lowered to impinge on the end of the test specimen.

The test continues until all burning of the specimen extinguishes (flameout). The specimen burn distance (flame front progression) is compared against a graph which contains heat flux levels from the 0" point to the 40" point. The heat flux at the distance burned is reported.

TEST PERFORMED: ASTM E 648 - Standard Test Method for Critical Radiant Flux of Floor Covering Systems Using a Radiant Heat Energy Source (NFPA Designation No. 253)

SPECIMEN PREPARATION:

- Each specimen was laid flat over a 1/4" Etera board (a cement asbestos substitute). No bonding agent was used. [PC: 48H]
- Each specimen was bonded to a 1/4" Etera board (a cement asbestos substitute) using multi-purpose carpet adhesive. [PC: 96H]
- Each specimen, with self adhesive backing, was bonded to a 1/4" Etera board (a cement asbestos substitute). [PC: 96H]
- Each specimen was placed over a rubber coated jute and animal hair 50 oz/yd² cushioning material. [PC: 48H]



Received:04/28/2017	Completed:05/09/2017	Letter: M	JB	P.O.#:	Test Report #:	3-18549-0-
Client's Identification	Lot No.: Temporary Surface Protection. Date of Mfg.: April 2017. Style: Skudo HT Mat. Composition: 100% Polyester Non-Woven Textile with High Traffic Coating. (see continuation)					
Tested For: Brendon Smith	Key Test: ASTM E 648 (BLDG) WIT				795	
Skudo USA 2330 Alberta Drive, # 200 Dallas, TX 75229	Tel: 1-(972)-993-0777		Ext:			
	Fax: 1-()- -					

RESULTS:

Specimen #	Furthest Progression of Flame Front at Flame Out		Critical Radiant Flux (watts/cm ²)	Time to Flame Front Flame Out* (mm:ss)
	(inches)	(cm)		
1	2.1	5.33	0.97	10:00
2	3.0	7.62	0.96	10:00
3	3.7	9.40	0.95	10:00
Avg:			0.96	

* Note: As measured from time zero (insertion of specimen into chamber).

Standard Deviation of Critical Radiant Flux: 0.01

CODE CLASSIFICATION -- As cited by:

- (1) The 2015 Edition of NFPA 101 Life Safety Code paragraph, 10.2.7.4
- (2) The 2015 Edition of NFPA 5000 Building Construction & Safety Code, paragraph 10.7.4
- (3) The 2015 Edition of the International Building Code, paragraph 804.2

Class I: Minimum 0.45 watts/cm²

Class II: Minimum 0.22 watts/cm²

OBSERVATIONS(of burning characteristics):

All Specimens

Specimen #'s _____

Premature ignition during the 5 min preheat, respectively for specimens 1, 2, and 3 (mm:ss): _____ : _____ , _____ : _____ , _____ : _____ .

Penetration of the flame to the substrate

Delamination

Blistering

Melting

Sagging

Shrinkage

OTHER: Describe: _____



Received:04/28/2017	Completed:05/09/2017	Letter: M	JB	P.O.#:	Test Report #:	3-18549-0-
Client's Identification	Lot No.: Temporary Surface Protection. Date of Mfg.: April 2017. Style: Skudo HT Mat. Composition: 100% Polyester Non-Woven Textile with High Traffic Coating. (see continuation)					
Tested For: Brendon Smith	Skudo USA 2330 Alberta Drive, # 200 Dallas, TX 75229			Key Test: ASTM E 648 (BLDG) WIT	795	
				Tel: 1-(972)-993-0777	Ext:	
				Fax: 1-()- -		

REMARKS: Test was conducted in the presence of Wayne Aaron (Texchem U.K. Limited).

CONCLUSION: Based on the above Results and Code Classification, the item tested is assigned a:

- Class I rating
- Class II rating
- Fails to achieve a minimum classification thereby rendering the product unsuitable in terms of code requirement

CERTIFICATION: I certify that the above results were obtained after testing specimens in accordance with the procedures and equipment specified above.



 AUTHORIZED SIGNATURE
 GOVMARK
 /pm /mo

TEXC-UK/SKU-TX/SKU-AU

(Page 3 of 3)

Douglas W. Lipp

MAY 10 2017





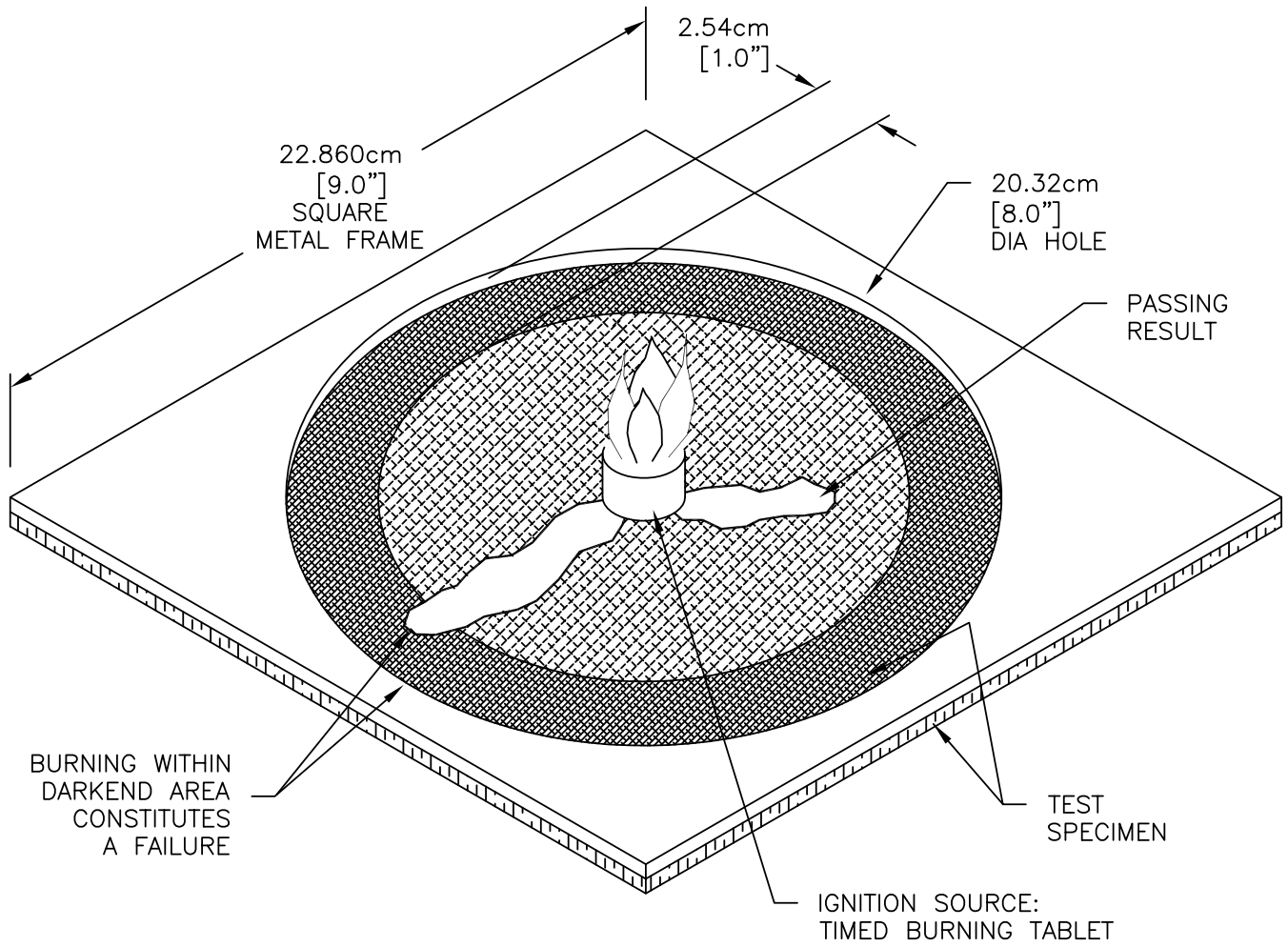

CFR TITLE 16 PART 1630

**Standard for the Surface Flammability
of Carpets and Rugs (FF 1-70)**



Received:04/28/2017	Completed:05/09/2017	Letter: MI	BG	P.O.#:	Test Report #:	3-18549-1-
Client's Identification	Lot No.: Temporary Surface Protection. Date of Mfg.: April 2017. Style: Skudo HT Mat. Composition: 100% Polyester Non-Woven Textile with High Traffic Coating. (see continuation)					
Tested For: Brendon Smith	Key Test: CFR 16 Part 1630/1631 WIT				255	
Skudo USA 2330 Alberta Drive, # 200 Dallas, TX 75229	Tel: 1-(972)-993-0777		Ext:			
	Fax: 1-()- -					

CLIENT'S IDENTIFICATION (continuation):

[Release paper removed prior to testing.]

LE: 2016 ; V 03/16 PC: 2H @ 105°C (221°F) + 1H (desiccator) NTR 5/16 /jd

TEST PERFORMED: CFR Title 16 Parts 1630 & 1631 (previously FF 1-70 & FF 2-70) - Standard for the Surface Flammability of Carpets & Rugs (Pill Test)

RESULTS REPORTED: Initially
 After 10 launderings AATCC Test Method 124
 After 10 alternative refurbishing cycles

BRIEF DESCRIPTION OF TEST: The ignition source is a small burning pill which is placed in the center of the material being tested. The technician observes the surface burning and charring (if any) along a 4.0" radius from the ignition point to the perimeter of a steel frame circle (flattening frame). The "Distance" measurement is the difference between the charred area (furthest point of burning) and the perimeter of the steel frame. The further the burning and charring progress, the lower the reported "Distance" value. Any reported "Distance" greater than 1.0" is passing. Any reported "Distance" of 1.0" or less is considered a failure.

RESULTS:

Specimen #	Distance (inches)
1	3.7
2	3.6
3	3.6
4	3.5
5	3.6
6	3.7
7	3.7
8	3.6

REMARKS: Test was conducted in the presence of Wayne Aaron (Texchem U.K. Limited).

ACCEPTANCE CRITERIA: "Distance" shall be greater than 1.0" for 7 or more specimens.

CONCLUSION: Based on the above Results and Acceptance Criteria, the item tested:

Complies; Does not comply

CERTIFICATION: I certify that the above results were obtained after testing specimens in accordance with the procedures and equipment specified above.

AUTHORIZED SIGNATURE

GOVMARK

/pm /mo

Douglas W. Lipp

MAY 10 2017

(Page 1 of 1)

TEXC-UK/SKU-TX/SKU-AU

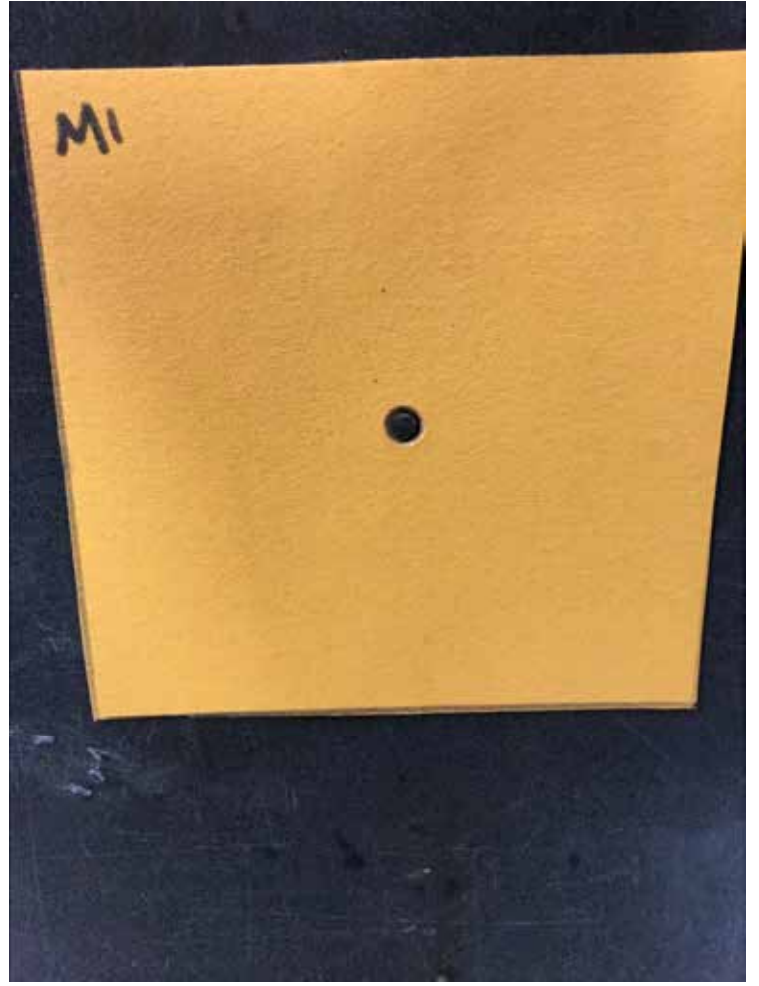

SKUDO Anti-Fungal Protect

Skudo Anti-Fungal Protect is a novel CIT, AOX and VOC-free, synergistic biocide specifically developed for the wet-state protection of water based formaldehyde sensitive products.



Chemical and Physical Characteristics

Composition:	A water based formulation of 2-methyl-4-isothiazolin-3-one (MIT) and 1,2-benzisothiazolin -3-one (BIT)
Appearance:	Yellow liquid
Odour:	Mild
Density (20°C):	1.030 g/cm ³
MIT Content:	2.35 - 2.65%
BIT Content:	2.35 - 2.65%
pH (20°C):	7.50 - 9.5
Solubility:	Miscible with water and most lower alcohols and glycols
Stability in application:	Stable in the presence of light, over the pH range 2 - 10 and up to 80°C

Biocidal Properties

Skudo Anti-Fungal Protect has a very broad microbiological activity spectrum showing truly synergistic activity against bacteria, moulds and yeasts that may cause infection and deterioration of water based products, including the following organisms:

Typical Spoilage Organisms

Bacteria

Achromobacter sp.
Aeromonas sp.
Alcaligenes sp.
Bacillus sp.
Escherichia coli
Flavobacterium sp.
Klebsiella sp.
Proteus sp.
Pseudomonas sp.
Streptomyces sp.

Moulds

Aspergillus sp.
Cephalosporium sp.
Cladosporium sp.
Fusarium sp.
Paecilomyces variotii
Penicillium funiculosum

Yeasts

Candida albicans
Rhodotorula sp.
Saccharomyces cerevisiae

Applications / Use Levels

Skudo Anti-Fungal Protect is suitable for the wet-state preservation of a wide range of aqueous products including paints, polymer emulsions, adhesives, ceramic glazes, fillers and sealants.

Skudo Anti-Fungal Protect is particularly effective in products having an alkaline pH and for the preparation of ecologically acceptable formulations.

Normal use concentrations are in the range 0.20 - 0.40%, depending on the product to be protected and the environmental conditions to which it will be exposed. The precise level required by a specific formulation can be determined by contacting your local representative.

Addition / Compatibility

Skudo Anti-Fungal Protect can be added at any time during production. However, it is advised to add it as early as possible to give protection throughout the production process. Care should be taken to ensure that temperature, pH and redox potential at the point of addition are suitable for stability of the product.

Skudo Anti-Fungal Protect is compatible with most formulations in which its application is recommended and it may be used in formaldehyde sensitive systems. Nevertheless, users are advised to carry out their own tests or seek further advice.

Performance Examples:

Untreated mat



Skudo HT mat with **Skudo Anti-Fungal Protect** incorporated into the coating

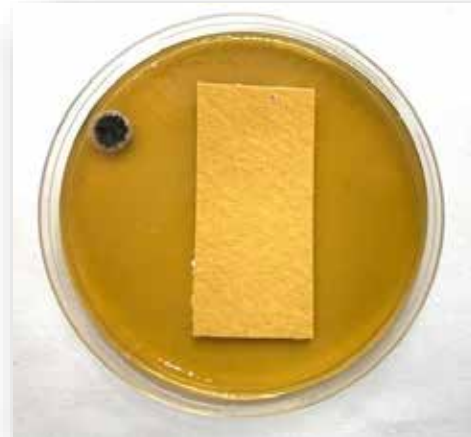

Skudo Basecoat containing **Skudo Anti-fungal Protect**

Wet Product

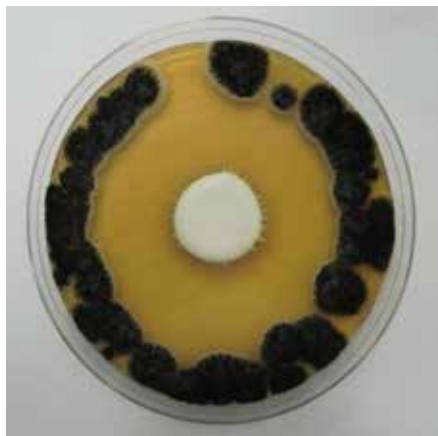

Dried Compound

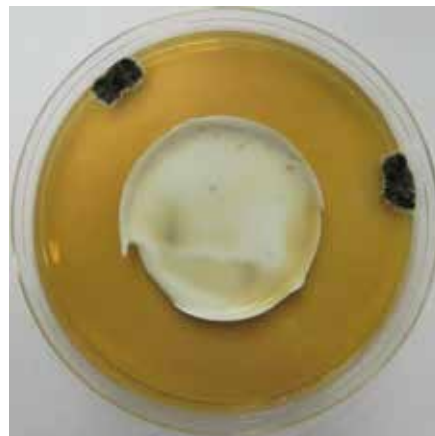

Each of the images shows a clear zone of inhibition when compared to the untreated fabric.

Packaging / Storage / Transport / Regulatory Approvals

Packaging:	25 and 200 kg plastic drums and 1,000 kg intermediate bulk containers
Shelf Life:	12 months from production date when stored at approximately 20°C
Storage:	Store in the original containers and protect from extremes of temperature. Skudo Anti-Fungal Protect is frost sensitive. At temperatures below 1°C BIT and BIT sodium salt may crystallise. However, after warming to a maximum temperature of 50°C any crystals formed will re-dissolve and the product can be used with no impairment of activity.
Transportation	Skudo Anti-Fungal Protect is classified as non-hazardous for transport
Regulatory Approvals:	The active substances of Skudo Anti-Fungal Protect have BfR chapters 14 and 36, FDA 21 CFRs 175.105, 176.170 and 176.180 and a wide range of other regulatory approvals. The US EPA registration number of the product itself is 67071-29.

Safety / Labelling / Toxicology

For detailed information on the toxicology and handling of **Skudo Anti-Fungal Protect** and advice on the labelling of products in which it may be used, please refer to the separate Material Safety Data Sheet.

The information contained in this leaflet is intended to be of assistance to users but is without guarantee. Variations can occur in application and users are advised to conduct their own tests. Suggestions for use neither give nor imply any freedom from patent infringement.



Reduce Your Risk!

Independent Slip Testing Services

GLOBAL PRODUCT CLASSIFICATION

TEST REPORT

SLIP RESISTANCE CLASSIFICATION OF
NEW PEDESTRIAN SURFACE MATERIALS

AS 4586-2013

Appendix A - Wet Pendulum Testing

Prepared For:

Skudo Group of Companies

Product Description:

Skudo Construction Mats, Safety Mat, Orange,
20x20cm

Test Date:

25-06-2018



Independent Slip Testing Services

+61 (0) 411 600 733 www.sliptesting.com.au | +64 (0) 279 735 266 www.sliptesting.co.nz
 +65 9390 2188 www.sliptesting.com.sg

Report Prepared for: Skudo Group of Companies
 PD Box 688 Mudgoorlea
 QLD 4213 Australia

Page 9: 1 of 1
Program #: 8006

Test Date: 23-06-2018
Test Site: Independent Slip Testing Services- Slip Resistance Laboratory (Labs QLD)
Testing Technician: M.Gosens
Testing Instrument: Pendulum Skid Tester with 45 rubber (slider 96)
 Testing Instrument Serial #: SKL380 (W3)

TESTING SPECIMEN DESCRIPTION, SIZE, COLOUR, TYPE, & COATING (if applicable)			
1.	1x Skudo Construction Mats, Safety Mat, Orange, Coating, Sample Size 20x20cm		
2.	1x Skudo Construction Mats, Safety Mat, Orange, Coating, Sample Size 20x20cm		
3.	1x Skudo Construction Mats, Safety Mat, Orange, Coating, Sample Size 20x20cm		
4.	1x Skudo Construction Mats, Safety Mat, Orange, Coating, Sample Size 20x20cm		
5.	1x Skudo Construction Mats, Safety Mat, Orange, Coating, Sample Size 20x20cm		
Surface Condition:	Fine Textured	Cleaning:	Tested as received
Finish/Uniform:	Uniform	Re Measure:	n/a
Environmental Conditions:	Air conditioning	Air Temp:	23 Deg.C
Direction of Test:	As indicated on underside of sample	Slope:	n/a

AS 4586-2013

INTERPRETATION OF THE WET PENDULUM RESULTS	
Classification	Pendulum mean BPN (45 rubber)
P5	>54
P4	45-54
P3	35-44
P2	25-34
P1	12-24
P0	<12

TEST RESULTS

Specimen	R1 Result:	62 BPN	Slider condition (P400):	64 BPN
	R2 Result:	60 BPN	Slider condition (Lapping):	63 BPN
	R3 Result:	60 BPN	Temperature adjustment:	n/a
	R4 Result:	60 BPN		
Skudo Construc:	R5 Result:	64 BPN		

CLASSIFICATION

CLASSIFICATION	PENDULUM MEAN BPN (45 rubber)
P5	61

The mean result of the five specimens reported rounded to nearest whole number
 *An individual result both below the mean classification and below the mean result value 20% shall be considered of lower classification

Maximum Slope Design Value (when dry):	9.5 deg.
Maximum Slope Design Value (when wet):	4 deg.

ANZI Code provides reference for ranges up to 2.5

DISCLAIMER

ISTS accepts no liability or responsibility for any action whatsoever that may arise from any part of this report and the publishing and issuing of this report. This test report is intended for advisory purposes only for the named recipient. Confidential claims, site related reports remain the property of ISTS. This report contains privileged and confidential information. The unauthorized reproduction of this report is prohibited.

Accredited for compliance with ISO/IEC 17025 testing and calibration. NATA is a signatory to the AFLAC mutual recognition arrangement for the mutual recognition of the equivalence of testing, calibration and inspection reports.

NATA Accreditation 00007

[Signature]
 Stephen Wickham



Testing was carried out using the Wet Pendulum Test Method in accordance with Australian Standard AS 4586-2013 Appendix A



Independent Slip Testing Services

+61 (0) 411 600 733 www.sliptesting.com.au | +64 (0) 279 735 266 www.sliptesting.co.nz | +65 9390 2188 www.sliptesting.com.sg

Independent Slip Testing Services
GLOBAL PRODUCT CLASSIFICATION

WET TEST RESULTS INTERPRETATION GUIDE (Part 1) - NATIONAL CONSTRUCTION CODE (AUSTRALIA)

***TABLE 2** Classification of Pedestrian Surface Materials according to the AS 4386-2013 wet pendulum test

CLASSIFICATION	Pendulum [®] mean BPN	
	Four 5 number [Slider 50]	TBL number [Slider 20]
P5	35-44	1-44
P4	45-54	42-44
P3	35-44	35-23
P2	25-34	20-24
P1	12-24	<20
P0	<02	-

INTERPRETING WET TEST RESULTS

How to interpret your wet test report...

Wet test results offer six possible outcomes- classification P0, P1, P2, P3, P4 or P5. The classification P0 reflects a lesser slip resistant surface, while P5 classification reflects the greatest slip resistance classification.

There are two parts to this interpretation guide- firstly the National Construction Code requirements, and secondly 'Other Performer Applications' recommendations.

For the 'Global Product Classification' test results refer additional slide below.

Step 1. Note the test location described in the left side column of your report, and the corresponding test result 'P' classification achieved (listed in the far right side column)

Step 2. From this interpretation guide, identify the most appropriately related location description described in either 'TABLE 3A' (Part 1) or 'TABLE 3B' (Part 2). Note the 'P' classification listed to the right of this description.

Step 3. 1. Study Construction Mats, Safety Mats, Drains, Coatings, Sample Size 2000mm slide. For 'Global Product Classification' test reports the 'TABLE 3A' or 'TABLE 3B' descriptions assist in identifying the product's suitability for various applications.

TREATMENT OPTIONS

For test results that achieve a result below recommendations, the following treatment options are available to increase slip resistance and Reduce Your Risk!

IPM-2020 with an anti-slip finish, allowing it to shed dirt, oil, grease, etc. of maximum level of investment we see our clients using to improve the slip resistance of various pedestrian surface materials.

Chemical products - Minimising detergent residue build up or other contaminants.
Acid etching - Increasing surface texture.
Coatings and sealers - Surface coatings in a range of penetrative types.
Surface texture - Castings, stones, sandblasting, shot blasting, etc.
Surface replacement - May be the most cost effective option in some instances.

An internet search for 'slip testing' will identify a large number of providers in your local area. ACC recommends searching a number of detailed proposals when considering treatments, outlining expected slip resistance improvements, visual changes, clean ability and life expectancy.

ADDITIONAL NOTES & REFERENCES

References

Table 3A - AS/NZS 4386:2013 'Wet Pendulum Test of Pedestrian Surface Materials'

Table 3 - AS 4386:2013 'Wet Pendulum Test of Pedestrian Surface Materials'

NB. The information provided is intended as a guide only, consult the relevant publications for further information to ensure to meet all requirements and recommendations.

TABLE 3A
Minimum wet pendulum test result classifications to meet National Construction Code requirements.

Location	Classification
Stair Treads and Stairway Landings in Buildings - Covered by NCC Volumes 1 - 2	P3 P4
1. Stair treads and a stairway landing (when wet)	P3
2. Stair treads and a stairway landing (when wet)	P4
Nosings for Stair Treads and Landings in Buildings - Covered by NCC Volumes 1 - 2	P3 P4
1. Dry stair tread, a stair non-slip nosing strip and a stairway landing	P3
2. Wet stair tread, a stair non-slip nosing strip and a stairway landing	P4
Ramps in Buildings - Covered by NCC Volumes 1 - 2	P3 P4 P4 P3
1. Ramps not steeper than 1:10 [4.1 degrees] gradient (when dry)	P3
2. Ramps not steeper than 1:10 [4.1 degrees] gradient (when wet)	P4
3. Ramps steeper than 1:10 [4.1 degrees] but not steeper than 1:8 [7.1 degrees] (when dry)	P4
4. Ramps steeper than 1:10 [4.1 degrees] up to but not steeper than 1:8 [7.1 degrees] (when wet)	P3



Reduce Your Risk!

Independent Slip Testing Services
GLOBAL PRODUCT CLASSIFICATION

Independent Slip Testing Services

+61 (0) 411 600 733 www.sliptesting.com.au | +64 (0) 279 735 266 www.sliptesting.co.nz | +65 9390 2188 www.sliptesting.com.sg

WET TEST RESULTS INTERPRETATION GUIDE (Part 2) - OTHER APPLICATIONS...NON NCC (AUSTRALIA)

TABLE 3B Minimum wet pendulum test result classifications for other applications where the NCC does not apply.

Location	Classification
External Pavements and Ramps	
1. External ramps including sloping driveways, ramps etc. steeper than 1 in 14 (4.3%)	P3
2. External ramps including sloping driveways, ramps etc., under 1:14 (4.3%), external car parks (eg. markets), external car park areas, external colonnades, embankments, pedestrian crossings, balconies, verandas, carports, driveways, courtyards and roof decks	P4
3. Undercover car parks	P3
Hotels, Offices, Public Buildings, Schools and Kindergartens	
1. Entrances and access areas including: - lobbies, offices, public construction sites, safety sheds, orange, drafting, Sample 5 - Traditional areas - Internal lift lobbies and common areas of public buildings	P3 P2 P1 (see Note 3)
2. Toilet facilities in offices, hotels and shopping centres	P3
3. Hotel in-parkment bathrooms, creches and toilets	P2
4. Hotel in-parkment kitchens and laundries	P2
Loading Docks, Commercial Kitchens, Cold Stores, Serving Areas	
1. Loading docks under cover and commercial kitchens	P3
2. Serving areas behind bars in public hotels and clubs, cold stores and freezers	P4
Supermarkets and Shopping Centres	
1. Food fresh markets, buffet food service areas, food courts and fast food dining areas in shopping centres	P3
2. Shop and supermarket fresh fruit and vegetables area	P3
3. Shop entry areas with external entrances	P3
4. Supermarket exits (except fresh food areas)	P1 (see Note 3)
5. Other separate shops inside shopping centres - wet	P3
6. Other separate shops inside shopping centres - dry	P1 (see Note 3)
Swimming Pools and Sporting Facilities	
1. Swimming pool ramps and stairs leading to water	P3
2. Swimming pool surrounds and communal shower rooms	P4
3. Communal changing rooms	P3
4. Undercover concourse areas of sports stadiums	P3
Hospitals and Aged Care Facilities	
1. Entrances and corridors in hospitals and aged care facilities	P3

TABLE 2 Classification of Pedestrian Surface Materials according to the AS 4398-2013 wet pendulum test

Classification	Pendulum ¹ mean RPN	
	Form 5 rubber (Slider 36)	TRL rubber (Slider 30)
P5	364	140
P4	45-54	40-44
P3	35-44	35-39
P2	25-34	20-34
P1	12-24	< 20
P0	<12	-

P1 (see Note 3)

Note 3:

The minimum classification listed in Table 3B is P2. It is inappropriate for Table 3B to list the lower classification, P0, since there is no lower limit on Classification P0.

Notwithstanding, some smooth and polished floor surfaces, which do not achieve Classification P1, may be considered to provide a safe walking environment for normal pedestrians walking at a reasonable pace, provided the surface is kept clean and dry; however, should these surfaces become contaminated by either wet or dry substances, or be used by pedestrians in any other manner, they may pose increased risk. Therefore, the type of environment, the in-service inspection of floors, other environmental considerations and how should be taken into account when selecting such products.

ADDITIONAL NOTES & REFERENCES

References

Table 3B-AS4398:2013 "Guide to the specification and testing of slip resistance of pedestrian surfaces" Standards Australia Limited 2014.

Table 3-AS 4398-2013 "Wet resistance classification of new pedestrian surface materials".

16. The information provided is intended as a public only, consultable reference and does not constitute a contract or warranty for the products or services mentioned.



TEST PRODUCT IMAGE

Product Description: Skudo Construction Mats , Safety mat
 , Orange, coating , 20x20cm
Test Date: 25-06-2018



TorTestSM Floor Friction Testing Service
SOTTER ENGINEERING CORPORATION
Consultants

26705 Luna Verde, Mission Viejo, CA 92691
Telephone/FAX: 949-582-0889

*Licensed by the State of California
Board for Professional Engineers
and Land Surveyors*

*Approved by City of Los Angeles
for testing slip resistance of flooring*

Flooring Slip Resistance Test Results — BOT 3000

Client: Skudo USA Inc.

Flooring: HT Skudo mat (Orange) mounted on fiber board

Report date: 9/16/12

Page 1 of 2

Sample no.: 1209-1412

Pieces tested: 1

Date tested: 9/15/12

Sample size: 13 in x 13 inches

Where tested: Sotter Engineering Corp. Lab

How and when sample obtained: Supplied by client 9/14/12

Static and dynamic coefficient of friction (COF) by BOT-3000 digital tribometer, using ANSI B101.1 and B101.3 test methods for wet friction. The same test methods, but without wetting, are used for dry friction.

Average static (S) and dynamic (D) coefficient of friction:

	AS RECEIVED	
	<u>Dry</u>	<u>Wet</u>
SCOF	1.00	1.00
DCOF	0.64	0.56

Results apply only to the sample tested. Values of 0.90 or higher may be lower than actual COF because the BOT-3000 cannot measure instantaneous values exceeding 1.00. High values indicate potentially good traction. Slip resistance can be affected by maintenance-related items including wear, floor coatings, buffing, and contamination, as well as footwear. Please see the next page for ANSI minimum recommendations regarding average SCOF and DCOF.

*This test report shall not be reproduced, except in full,
without the written approval of Sotter Engineering Corporation.*

The BOT-3000 uses 28 mm (1.1 inch) wide curved laboratory-grade artificial hard rubber test feet. Further information on the BOT-3000, and a video demonstration of the instrument, can be found at

<http://www.safetydirectamerica.com/BOT-3000.html>

ANSI denotes the American National Standards Institute — a private, not-for-profit organization. Their method B 101.1 is "Test Method for Measuring Wet SCOF of Common Hard-Surfaced Floor Materials." The method quotes the following reference values:

<u>Wet average SCOF value</u>	<u>Available traction</u>
≥ 0.60	High traction — lower probability of slipping
0.40 – <0.60	Moderate traction — increased probability of slipping
<0.40	Minimal available traction — higher probability of slipping

ANSI B101.3 is "Test Method for Measuring Wet DCOF of Common Hard-Surface Floor Materials." The method quotes the following reference values:

<u>Wet average DCOF value</u>	<u>Slip resistance potential</u>
0.43 or higher (level floor) 0.46 or higher (inclines)	Lower probability of slipping
0.30–0.42 (level floor) 0.30–0.45 (inclines)	Increased probability of slipping
Less than 0.30	Higher probability of slipping

Sotter Engineering Corporation, and most leading slip-and-fall forensic experts, believe that dynamic friction is a more reliable way of assessing wet slip potential than is static friction.

Individual values of wet DCOF for the sample, as required by ANSI B101.3:

0 degrees	57	58	57	57	58
90 degrees	58	56	56	55	57
180 degrees	56	55	55	55	58
270 degrees	54	53	54	52	53

Respectfully submitted,
SOTTER ENGINEERING CORPORATION

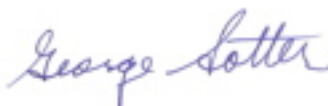

J. George Sotter, P.E., Ph.D.
President



*This test report shall not be reproduced, except in full,
without the written approval of Sotter Engineering Corporation.*

TorTestSM Floor Friction Testing Service
SOTTER ENGINEERING CORPORATION
Consultants

26705 Luna Verde, Mission Viejo, CA 92691
Telephone/FAX: 949-582-0889

*Licensed by the State of California
Board for Professional Engineers
and Land Surveyors*

*Approved by City of Los Angeles
for testing slip resistance of flooring*

Flooring Slip Resistance Test Results — BOT 3000

Client: Skudo USA Inc.

Flooring: MT Skudo mat (Yellow) mounted on fiber board Report date: 9/16/12

Page 1 of 2 Sample no.: 1209-1413 Pieces tested: 1

Date tested: 9/15/12 Sample size: 13 in x 13 inches

Where tested: Sotter Engineering Corp. Lab

How and when sample obtained: Supplied by client 9/14/12

Static and dynamic coefficient of friction (COF) by BOT-3000 digital tribometer, using ANSI B101.1 and B101.3 test methods for wet friction. The same test methods, but without wetting, are used for dry friction.

Average static (S) and dynamic (D) coefficient of friction:

	AS RECEIVED	
	<u>Dry</u>	<u>Wet</u>
SCOF	1.00	1.00
DCOF	0.68	0.64

Results apply only to the sample tested. Values of 0.90 or higher may be lower than actual COF because the BOT-3000 cannot measure instantaneous values exceeding 1.00. High values indicate potentially good traction. Slip resistance can be affected by maintenance-related items including wear, floor coatings, buffing, and contamination, as well as footwear. Please see the next page for ANSI minimum recommendations regarding average SCOF and DCOF.

*This test report shall not be reproduced, except in full,
without the written approval of Sotter Engineering Corporation.*

The BOT-3000 uses 28 mm (1.1 inch) wide curved laboratory-grade artificial hard rubber test feet. Further information on the BOT-3000, and a video demonstration of the instrument, can be found at

<http://www.safetydirectamerica.com/BOT-3000.html>

ANSI denotes the American National Standards Institute — a private, not-for-profit organization. Their method B 101.1 is "Test Method for Measuring Wet SCOF of Common Hard-Surfaced Floor Materials." The method quotes the following reference values:

<u>Wet average SCOF value</u>	<u>Available traction</u>
≥ 0.60	High traction — lower probability of slipping
0.40 – <0.60	Moderate traction — increased probability of slipping
<0.40	Minimal available traction — higher probability of slipping

ANSI B101.3 is "Test Method for Measuring Wet DCOF of Common Hard-Surface Floor Materials." The method quotes the following reference values:

<u>Wet average DCOF value</u>	<u>Slip resistance potential</u>
0.43 or higher (level floor) 0.46 or higher (inclines)	Lower probability of slipping
0.30–0.42 (level floor) 0.30–0.45 (inclines)	Increased probability of slipping
Less than 0.30	Higher probability of slipping

Sotter Engineering Corporation, and most leading slip-and-fall forensic experts, believe that *dynamic* friction is a more reliable way of assessing wet slip potential than is *static* friction.

Individual values of wet DCOF for the sample, as required by ANSI B101.3:

0 degrees	63	64	63	63	64
90 degrees	66	61	62	58	65
180 degrees	67	67	68	64	65
270 degrees	65	61	64	62	62

Respectfully submitted,
SOTTER ENGINEERING CORPORATION

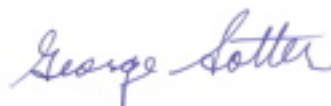

J. George Sotter, P.E., Ph.D.
President



*This test report shall not be reproduced, except in full,
without the written approval of Sotter Engineering Corporation.*

FLAMMABILITY TEST REPORT

Report No.: LEI17020002809A

Date Received: 20/02/17

Date Tested: 23/01/17

Date Issued: 23/01/17

Company Name & Address: TEXCHEM UK LTD
HOLMES MILL
HOLMES STREET
ROCHDALE
0L12 6AQ

Contact Name: WAYNE AARON

Sample Details

Reference No.: 5% Addition
Order No.: Not stated
Style No.: New FR Addition
Batch No.: Not stated
Quality: HT Tack Mat
Colour: Orange
Supplier: Skudo
Intended Use: Floor Protection
Quoted Fibre Composition: Polyester Nonwoven
Retailer: Not stated
Sample Description: Orange / grey coloured flooring

Test Method	Result
16 CFR 1630	*PASS

* **Please note:** The backing paper was removed prior to testing at the request of the customer.

.....
~~STEVEN OWEN~~
(Chemical Technologist)

.....
ANDREW HALLETT
(Flammability Team Leader)

.....
~~CAROLE SPOWART~~
(Flammability Technician)

.....
SIMON CHEE
(Operations Manager)

FLAMMABILITY TEST REPORT

Test Specification

Test method 16 CFR 1630
Criterion of ignition: Methenamine tablet

Pre - Treatments

None

Conditioning

Prior to testing: 2 hours at $105 \pm 5^{\circ}\text{C}$ followed by a minimum of 1 hour over desiccant
At time of testing: Temperature between 15°C & 30°C . Relative humidity between 15% & 80%

Test results

The results relate only to the behaviour of specimens after the application of a small source of ignition; they shall not be used as a means of assessing how the product will contribute to an established fire.

Specimen Tested	Minimum distance from the flattening frame to the charred area (mm)	Flaming Ceased	Afterglow Ceased	Smoking Ceased	Time effects of ignition reached the flattening frame
1	94	109	N/A	115	DNRCR
2	92	103	N/A	112	DNRCR
3	93	99	N/A	105	DNRCR
4	91	105	N/A	110	DNRCR
5	92	102	N/A	107	DNRCR
6	94	107	N/A	113	DNRCR
7	93	102	N/A	108	DNRCR
8	93	104	N/A	109	DNRCR

N/A = Not applicable

DNI = Did not ignite

FE= Forcibly extinguished after charred area reached the flattening ring

DNRCR = Did Not Reach Clamping Ring

This report is made solely on the basis of your instructions and/or information and materials supplied by you. It is not intended to be a recommendation for any particular course of action. Intertek does not accept a duty of care or any other responsibility to any person other than the Client in respect of this report and only accepts liability to the Client insofar as is expressly contained in the terms and conditions governing Intertek's provision of services to you. Intertek makes no warranties or representations either express or implied with respect to this report save as provided for in those terms and conditions. We have aimed to conduct the Review on a diligent and careful basis and we do not accept any liability to you for any loss arising out of or in connection with this report, in contract, tort, by statute or otherwise, except in the event of our gross negligence or willful misconduct.



Reduce Your Risk!

Independent Slip Testing Services

GLOBAL PRODUCT CLASSIFICATION

TEST REPORT

SLIP RESISTANCE CLASSIFICATION OF
NEW PEDESTRIAN SURFACE MATERIALS

AS 4586-2013

Appendix A - Wet Pendulum Testing

Prepared For:

Skudo Group of Companies

Product Description:

Skudo Tack-Mat LT

Test Date:

13-09-2018



Independent Slip Testing Services

+61 (0) 411 600 733 www.sliptesting.com.au | +64 (0) 279 735 266 www.sliptesting.co.nz
 +65 9390 2188 www.sliptesting.com.sg

Report Prepared for:

Skate Group of Companies
 PO Box 688
 Mudgoorook QLD 4213

Page #: 1 of 1
 Program #: R005

Test Date:

13-09-2018

Test Site:

Independent Slip Testing Services- Slip Resistance Laboratory (Labs QLD)

Testing Technician:

M.Watson

Testing Instrument:

Pendulum Skid Tester with Slider 96 (45) rubber
 Testing Instrument Serial #: SKL3801 (W3)

TESTING SPECIMEN DESCRIPTION, SIZE, COLOUR, TYPE, & COATING (if applicable)

1. 1 x Skate Tack-Mat, Grey, Sample size 200x200mm
2. 1 x Skate Tack-Mat, Grey, Sample size 200x200mm
3. 1 x Skate Tack-Mat, Grey, Sample size 200x200mm
4. 1 x Skate Tack-Mat, Grey, Sample size 200x200mm
5. [4 x samples tested in 5 x locations]

Surface Condition:	Treated	Cleaning:	Tested as received
Finish/Uniform:	Uniform	Br. Mark:	n/a
Environmental Conditions:	Air conditioning	Air Temp:	22 Deg.C
Direction of Test:	As indicated on underside of sample	Slope:	n/a

AS 4586-2013

INTERPRETATION OF THE WET PENDULUM RESULTS

Classification	Pendulum mean BPN Slider 96 (45) rubber
P5	>54
P4	45-54
P3	35-44
P2	25-34
P1	12-24
P0	<12

TEST RESULTS

Specimen	R1 Result:	50 BPN	Slider condition (P400):	82 BPN
	R2 Result:	48 BPN	Slider condition (Lapping):	59 BPN
	R3 Result:	49 BPN	Temperature adjustment:	n/a
	R4 Result:	50 BPN		
	R5 Result:	51 BPN		

CLASSIFICATION

CLASSIFICATION	PENDULUM MEAN BPN (45 rubber)
P4	50

The mean result of the five specimens reported (rounded to nearest whole number)

*An individual result both below the mean classification and below the mean result value 20% shall be considered of lower classification

Maximum Slope Design Value (when dry):	4 deg
Maximum Slope Design Value (when wet):	3 deg

*AISC Code provides reference for ranges up to 2.5

DISCLAIMER

ISTS accepts no and holds no responsibility for any actions whatsoever that may arise as a result of the tests and the provision and form of this test report. This test report is intended for viewing purposes only for the named recipient. Viewing views. This slip test report remains the property of ISTS. This report contains privileged and confidential information. The intellectual reproduction

Accredited for compliance with ISO/IEC 17025 testing and calibration. NATA is a signatory to the APLAC mutual recognition arrangement for the mutual recognition of the equivalence of testing, calibration and inspection reports.



M. Watson
 Matthew Watson

Testing was carried out using the Wet Pendulum Test Method
 in accordance with Australian Standard AS 4586-2013 Appendix A



Reduce Your Risk!

Independent Slip Testing Services
GLOBAL PRODUCT CLASSIFICATION

Independent Slip Testing Services

+61 (0) 431 600 755 www.sliptesting.com.au | +64 (0) 279 755 366 www.sliptesting.co.nz | +65 9390 2188 www.sliptesting.com.sg

WET TEST RESULTS INTERPRETATION GUIDE (Part 1)- NATIONAL CONSTRUCTION CODE (AUSTRALIA)

INTERPRETING WET TEST RESULTS

How to interpret your wet test report...

Wet test results offer six possible outcomes- classifications P1, P2, P3, P4 or P5.

The classification P5 reflects a lesser slip resistant surface, while P1 classification reflects the greatest slip resistance classification.

There are two parts to this interpretation guide- Firstly the National Construction Code requirements, and secondly Other Particular Applications' recommendations.

For the 'Global Product Classification' test results refer additional slide below.

Step 1. Note the test location described in the left side column of your report, and the corresponding test result P classification achieved (listed in the far right side column)

Step 2. From this interpretation guide, identify the most appropriately related location description described in either TABLE 3A (Part 1) or TABLE 3B (Part 2). Note the P classification listed to the right of this description.

Step 3. If the test result classification listed meets (or exceeds) the related P classification from TABLE 3A or TABLE 3B, the test surface is meeting the relevant requirement.

Slide: For 'Global Product Classification' test reports the TABLE 3A or TABLE 3B classifications assist in identifying the products suitability for various applications.

TABLE 3A NATIONAL CONSTRUCTION CODE COMPLIANCE CLASSIFICATIONS

Minimum wet pendulum test result classifications to meet National Construction Code requirements.

Location	Classification
Stair Treads and Stairway Landings in Buildings - Covered by NCC Volumes 1 - 2	P3 P4
1. Stair treads and a stairway landing (when dry)	P3
2. Stair treads and a stairway landing (when wet)	P4
Nosings for Stair Treads and Landings in Buildings - Covered by NCC Volumes 1 - 2	P3 P4
1. Dry stair tread, a stair nosing and a stairway landing	P3
2. Wet stair tread, a stair nosing and a stairway landing	P4
Ramps in Buildings - Covered by NCC Volumes 1 - 2	P3 P4 P4 P3
1. Ramps not steeper than 1:10 (4.1 degrees) gradient (when dry)	P3
2. Ramps not steeper than 1:10 (4.1 degrees) gradient (when wet)	P4
3. Ramps steeper than 1:10 (4.1 degrees) to but not steeper than 1:8 (7.1 degrees) (when dry)	P4
4. Ramps steeper than 1:10 (4.1 degrees) to but not steeper than 1:8 (7.1 degrees) (when wet)	P3

Form B17.3, Revision Date: 04-11-2017

*TABLE 2. Classification of Pedestrian Surface Materials according to the AS 4586-2013 wet pendulum test

CLASSIFICATION	Pendulum ¹ mean RPN	
	Four S number (Slider 50)	TPL number (Slider 30)
P5	3-4	1-4
P4	45-54	40-44
P3	55-64	50-54
P2	75-84	70-74
P1	12-24	12-24
P0	<02	-

TREATMENT OPTIONS

For test results that achieve a result below recommendations, the following treatment options are available to increase slip resistance and Reduce Your Risk!

NOTE: THIS table only an AVERAGE table, following is a short list of common types of treatments we see our clients using to improve the slip resistance of various pedestrian surface materials.

- Cleaning procedures** Minimising detergent residue build up or other contaminants.
- Acid etching** Increasing surface texture.
- Coatings and sealers** Surface coatings and penetrative types.
- Surface treatment** Coatings, etchants, sandblasting, shot blasting, etc.
- Surface replacement** May be the most cost effective option in some instances.

An internet search for 'Slip Testing Australia' will identify further treatment options available in your local area. NCC recommends seeking a number of detailed proposals when considering treatments, outlining expected slip resistance improvements, visual changes, clear ability and life expectancy.

ADDITIONAL NOTES & REFERENCES

References

Table 3A- NCC Volume 2014 relate to the specification and testing of slip resistance of pedestrian surfaces' Standards Australia Limited 2014.

Table 2- AS 4586-2013 'The minimum classification of new pedestrian surface materials'.

NB. The information provided is intended as a guide only, consult the referenced publications for further information in regards to measurement results and recommendations.



Reduce Your Risk!

Independent Slip Testing Services

GLOBAL PRODUCT CLASSIFICATION

Independent Slip Testing Services

+61 (0) 411 660 733 www.sliptesting.com.au | +64 (0) 279 735 266 www.sliptesting.co.nz | +65 9390 2188 www.sliptesting.com.sg

WET TEST RESULTS INTERPRETATION GUIDE (Part 2)- OTHER APPLICATIONS...NON NCC (AUSTRALIA)

TABLE 3B Minimum wet pendulum test result classifications for other applications where the NCC does not apply.

Location	Classification
External Pavements and Ramps	
1. External ramps including sloping driveways, footpaths etc. steeper than 1 in 14 (4.3%)	P3
2. External ramps including sloping driveways, footpaths, etc., under 1:14 (4.3%), external car parks areas (eg. markets), external car park areas, external caravans, embankments, pedestrian crossings, motorways, terminals, airports, driveways, courtyards and roof decks	P4
3. Undercover car parks	P5
Hotels, Offices, Public Buildings, Schools and Kindergartens	
1. Entries and access areas including - lobbies, offices, public buildings, schools, kindergartens, internal lift lobbies and common areas of public buildings	P3 P2 P1 (see Note 3)
2. Toilet facilities in offices, hotels and shopping centres	P3
3. Hotel apartment bathrooms, corridors and balconies	P2
4. Hotel apartment kitchens and laundries	P2
Loading Docks, Commercial Kitchens, Cold Stores, Serving Areas	
1. Loading docks under cover and commercial kitchens	P3
2. Serving areas behind bars in public hotels and clubs, cold stores and freezers	P4
Supermarkets and Shopping Centres	
1. Food fresh markets, buffet food service areas, food courts and food fresh dining areas in shopping centres	P3
2. Shop and supermarket fresh fruit and vegetables area	P3
3. Shop entry areas with external entrances	P3
4. Supermarket aisles (except fresh food areas)	P3 (see Note 3)
5. Other separate shops inside shopping centres - wet	P3
6. Other separate shops inside shopping centres - dry	P3 (see Note 3)
Swimming Pools and Sporting Facilities	
1. Swimming pool ramps and stairs leading to water	P3
2. Swimming pool surrounds and communal shower rooms	P4
3. Communal changing rooms	P3
4. Undercover communal areas of sports sheds etc	P3
Hospitals and Aged Care Facilities	
1. Bathrooms and corridors in hospitals and aged care facilities	P3
2. Waiting and corridors in hospital and aged care facilities	P2

Form ISTS-A, Revision Date: 04-11-2017

***TABLE 2** Classification of Pedestrian Surface Materials according to the AS 4586-2013 wet pendulum test

Classification	Pendulum ¹ mean RFR	
	Four S number [Slider 36]	TPL number [Slider 33]
P5	3-54	1-40
P4	45-54	40-44
P3	35-44	35-39
P2	25-34	28-34
P1	12-24	< 28
P0	< 12	-

P1 (see Note 3)

Note 3:

The minimum classification listed in Table 3B is P2. It is inappropriate for Table 3B to list the lower classification, P0, since there is no lower limit on Classification P0.

Methodology: some smooth and polished floor surfaces, which do not achieve Classification P1, may be considered to provide a safe walking environment for normal pedestrians walking at a moderate pace, provided the surface is kept clean and dry. However, should these surfaces become contaminated by either wet or dry materials, or be used by pedestrians in any other manner, then they may become unsafe. Therefore, the type of maintenance, the frequency of inspections of floors, other environmental conditions and how should be taken into account when selecting such products.

ADDITIONAL NOTES & REFERENCES

References

Table 3B-1 (2013) AS 4586-2013 "Guide to the specification and testing of slip resistance of pedestrian surfaces" Standards Australia Limited 2014.

Table 2-40 (2013) AS 4586-2013 "Slip resistance classification of new pedestrian surface materials".

16. The information provided is intended as a guide only, consult the referenced publications for their information in regard to measurement methods and recommendations.



TEST PRODUCT IMAGE

Product Description: Skudo Tack-Mat LT

Test Date: 13-09-2018





Reduce Your Risk!

Independent Slip Testing Services

GLOBAL PRODUCT CLASSIFICATION

TEST REPORT

SLIP RESISTANCE CLASSIFICATION OF
NEW PEDESTRIAN SURFACE MATERIALS

AS 4586-2013

Appendix A - Wet Pendulum Testing

Prepared For:

Skudo Group of Companies

Product Description:

Skudo All Terrain Mat

Test Date:

13-09-2018



Independent Slip Testing Services

+61 (0) 411 600 733 www.sliptesting.com.au | +64 (0) 279 735 266 www.sliptesting.co.nz
 +65 9390 2188 www.sliptesting.com.sg

Report Prepared for:

Shade Group of Companies
 PO Box 688
 Mudgee NSW 2853

Page #: 1 of 1
 Program #: M005

Test Date:
 Test Site:
 Testing Technician:
 Testing Instrument:

13-09-2018
 Independent Slip Testing Services- Slip Resistance Laboratory (Labs QLD)
 M. Walton
 Pendulum Skid Tester with Slider 96 (45) rubber
 Testing Instrument Serial #: SKL1801 (W3)

TESTING SPECIMEN DESCRIPTION, SIZE, COLOUR, TYPE, & COATING (if applicable)	
1.	1 x Shade All Terrain Mat, Green, Sample size 200x200mm
2.	1 x Shade All Terrain Mat, Green, Sample size 200x200mm
3.	1 x Shade All Terrain Mat, Green, Sample size 200x200mm
4.	1 x Shade All Terrain Mat, Green, Sample size 200x200mm
5.	[4 x samples tested in 5 x locations]

Surface Condition:	Treated	Cleaning:	Tested as received
Floor/Uniform:	Uniform	Re-Meas:	n/a
Environmental Conditions:	Air conditioning	Air Temp:	22 Deg.C
Direction of Test:	As indicated on underside of sample	Slip:	n/a

AS 4586-2013

INTERPRETATION OF THE WET PENDULUM RESULTS	
Classification	Pendulum mean BPN Slider 96 (45) rubber
P5	>54
P4	45-54
P3	35-44
P2	25-34
P1	12-24
P0	<12

TEST RESULTS

Specimen	R1 Result:	44 BPN	Slider condition (P400):	82 BPN
	R2 Result:	45 BPN	Slider condition (Lapping):	58 BPN
	R3 Result:	45 BPN	Temperature adjustment:	n/a
	R4 Result:	45 BPN		
	R5 Result:	45 BPN		

CLASSIFICATION

CLASSIFICATION	PENDULUM MEAN BPN (45 rubber)
P4	45

The mean result of the five specimens reported (rounded to nearest whole number)
 *An individual result both below the mean classification and below the mean result value 20% shall be considered of lower classification

Maximum Slope Design Value (when dry):	4 deg
Maximum Slope Design Value (when wet):	N/A

*NCE: Check previous reference for ranges up to 2.8

Inspector M. Walton

DISCLAIMER:
 ISTS accepts no and holds no responsibility for any actions whatsoever that may arise as a result of the tests and the publication and dissemination of the test report. The test report is intended for the intended purpose only and for the named recipient (client) only. The slip test report remains the property of ISTS. This report contains privileged and confidential information. The unauthorised reproduction of this report is strictly prohibited.

Accredited for compliance with ISO/IEC 17025 testing and calibration. NATA is a signatory to the APLAC mutual recognition arrangement for the mutual recognition of the equivalence of testing, calibration and inspection reports.



Testing was carried out using the Wet Pendulum Test Method in accordance with Australian Standard AS 4586-2013 Appendix A



Reduce Your Risk!

Independent Slip Testing Services
GLOBAL PRODUCT CLASSIFICATION

Independent Slip Testing Services

+61 (0) 411 600 733 www.sliptesting.com.au | +64 (0) 279 733 266 www.sliptesting.co.nz | +65 9390 2188 www.sliptesting.com.sg

WET TEST RESULTS INTERPRETATION GUIDE (Part 1)- NATIONAL CONSTRUCTION CODE (AUSTRALIA)

INTERPRETING WET TEST RESULTS

How to interpret your wet test result...
 Wet test results offer six possible outcomes- classification P1, P2, P3, P4 or P5.
 The classification P1 reflects a lower slip resistant surface, while P5 classification reflects the greatest slip resistance classification.
 There are two parts to this interpretation guide- Firstly the National Construction Code requirements, and secondly 'Other Product Applications' recommendations.
 For the 'Related Product Classification' test results refer additional slide below.
Step 1. Note the test location described in the left side column of your report, and the corresponding test result 'P' classification achieved (listed in the far right side column)
Step 2. From this interpretation guide, identify the most appropriately related location description described in either 'TABLE 3A' (Part 1) or 'TABLE 3B' (Part 2). Note the 'P' classification listed to the right of this description.
Step 3. If the test result classification listed meets (or exceeds) the related 'P' classification from 'TABLE 3A' or 'TABLE 3B', the test surface is meeting the relevant requirement.
Slide. For 'Global Product Classification' test reports the 'TABLE 3A' or 'TABLE 3B' descriptions assist in identifying the product's suitability for various applications.

TABLE 3A NATIONAL CONSTRUCTION CODE COMPLIANCE CLASSIFICATIONS

Location	Classification
Stair Treads and Stairway Landings in Buildings - Covered by NCC Volumes 1 - 2 Minimum wet pendulum test result classifications to meet National Construction Code requirements.	
1. Stair treads and a stairway landing (when dry)	P3
2. Stair treads and a stairway landing (when wet)	P4
Nosings for Stair Treads and Landings in Buildings - Covered by NCC Volumes 1 - 2	
1. Dry stair tread, a stair non-slip nosing strip and a stairway landing	P3
2. Wet stair tread, a stair non-slip nosing strip and a stairway landing	P4
Ramps in Buildings - Covered by NCC Volumes 1 - 2	
1. Ramps not steeper than 1:14 (4.1 degrees) gradient (when dry)	P3
2. Ramps not steeper than 1:14 (4.1 degrees) gradient (when wet)	P4
3. Ramps steeper than 1:14 (4.1 degrees) but not steeper than 1:8 (7.1 degrees) (when dry)	P4
4. Ramps steeper than 1:14 (4.1 degrees) up to but not steeper than 1:8 (7.1 degrees) (when wet)	P3

Form B17.3, Revision Date 04-11-2017

*TABLE 2 Classification of Pedestrian Surface Materials according to the AS 4386-2013 wet pendulum test

CLASSIFICATION	Pendulum [®] mean BPN	
	Four 5 rubber [Slider 50]	TBL rubber [Slider 30]
P5	3-54	1-44
P4	45-54	42-44
P3	35-44	35-38
P2	25-34	20-34
P1	12-24	4-28
P0	<12	-

TREATMENT OPTIONS

For test results that achieve a result below recommendations, the following treatment options are available to increase slip resistance and Reduce Your Risk!

IPMS 2020 with an anti-slip additive is a sheet of ceramic (one of treatments we use our clients using to improve the slip resistance of various pedestrian surface materials.

- Chemical products** - Minimising detergent residue build up or other contaminants.
 - Acid etching** - Increasing surface texture.
 - Coatings and sealers** - Surface coatings and penetrative types.
 - Surface texture** - Castings, etchants, sandblasting, shot blasting, etc.
 - Surface replacement** - May be the most cost effective option in some instances.
- An internet search for 'Slip Testing Australia' will identify other potential providers in your local area. NCC recommends searching a number of detailed proposals when considering treatments, outlining expected slip resistance improvements, visual changes, clean ability and life expectancy.**

ADDITIONAL NOTES & REFERENCES

- References**
 - Table 3A - AS/NZS 4386:2013 'AS 4386-2013 Wet Pendulum Test of Pedestrian Surface Materials' Standards Australia Limited 2013.
 - Table 3 - AS 4386:2013 'Wet Pendulum Classification of New Pedestrian Surface Materials'.
- NB.** The information provided is intended as a guide only, consult the relevant publications for further information or refer to measurement results and recommendations.



Reduce Your Risk!

Independent Slip Testing Services

GLOBAL PRODUCT CLASSIFICATION

Independent Slip Testing Services

+61 (0) 431 600 733 www.sliptesting.com.au | +64 (0) 279 735 266 www.sliptesting.co.nz | +65 9390 2188 www.sliptesting.com.sg

WET TEST RESULTS INTERPRETATION GUIDE (Part 2)- OTHER APPLICATIONS...NON NCC (AUSTRALIA)

● **TABLE 3B**

Minimum wet pendulum test result classifications for other applications where the NCC does not apply.

Location	Classification
External Pavements and Ramps	
1. External ramps (including: sloping driveways, footpaths etc. steeper than 3 in 10 (4.3%))	P5
2. External ramps (including: sloping driveways, footpaths, etc., under 3.0 (4.3%), external car parks (eg. markets), external car park areas, external colonnades, walkways, pedestrian crossings, balconies, verandas, carports, driveways, courtyards and roof decks	P4
3. Undercover car parks	P3
Hotels, Offices, Public Buildings, Schools and Kindergartens	
1. Entries and access areas including: - lobbies, offices, public buildings, schools, kindergartens, - internal lift lobbies and common areas of public buildings	P5 P2 P1 (see Note 3)
2. Toilet facilities in offices, hotels and shopping centres	P5
3. Hotel apartment: bathrooms, corridors and toilets	P2
4. Hotel apartment: kitchens and laundries	P2
Loading Docks, Commercial Kitchens, Cold Stores, Serving Areas	
1. Loading docks under cover and commercial kitchens	P5
2. Serving areas behind bars in public: hotels and clubs, cold stores and freestore Supermarkets and Shopping Centres	P4
3. Food food markets, buffet food service areas, food courts and food food dining areas in shopping centres	P3
2. Shop and supermarket fresh fruit and vegetables area	P3
3. Shop entry areas with external entrances	P3
4. Supermarket aisles (except fresh food areas)	P1 (see Note 3)
5. Other separate shops inside shopping centres - wet	P3
6. Other separate shops inside shopping centres - dry	P1 (see Note 3)
Swimming Pools and Sporting Facilities	
1. Swimming pool ramps and stairs leading to water	P3
2. Swimming pool surrounds and communal shower rooms	P4
3. Communal changing rooms	P5
4. Undercover concourse areas of sports stadiums	P3
Hospitals and Aged Care Facilities	
1. Entrances and corridors in hospitals and aged care facilities	P3
2. Wards and corridors in hospital and aged care facilities	P2

*TABLE 2 Classification of Pedestrian Surface Materials according to the AS 4286-2013 wet pendulum test

Classification	Pendulum ¹ mean BPN	
	Four S number [Slider 36]	TPL number [Slider 30]
P5	≥64	≥40
P4	45-54	40-44
P3	35-44	35-39
P2	25-34	20-34
P1	12-24	4-20
P0	<12	-

Note 3:
The minimum classification listed in Table 3B is P1. It is inappropriate for Table 3B to list the lower classification, P0, since there is no lower limit on Classification P0.

Note: notwithstanding some smooth and polished floor surfaces, which do not achieve Classification P1, may be considered to provide a safe walking environment for normal pedestrian walking at a reasonable pace, provided the surface is kept clean and dry; however, should these surfaces become contaminated by oil or dry materials, or be used by pedestrians in any other manner, then they may become unsafe. Therefore, the type of environment, the in-service inspection of floors, other environmental conditions and how should be taken into account when selecting such products.

P1 (see Note 3)

References
 - Table 3B-1 (AS 4286-2013) Guide to the specification and testing of slip resistance of pedestrian surfaces' Standards Australia Limited 2014.
 - Table 3-10 (AS 4286-2013) 'slip resistance classification of new pedestrian surface materials'.
 - Note: The information provided is intended as a guide only, consultable reference publications for further information to report to measurement results and recommendations.

ADDITIONAL NOTES & REFERENCES



TEST PRODUCT IMAGE

Product Description: Skudo All Terrain Mat

Test Date: 13-09-2018



TEST REPORT

No. : GZAT151201

Date : Dec 21, 2015

Page: 1 of 7

CUSTOMER NAME:

SKUDO MANUFACTURING PTY LTD

The following sample's information(s) was/ were submitted and identified on behalf of the client as:

Sample Name : ALL TERRIAN MAT
SGS Ref No. : GZIN1512054098MR
Date of Receipt : Dec 14, 2015
Testing Start Date : Dec 14, 2015
Testing End Date : Dec 21, 2015
Test Result(s) : For further details, please refer to the following page(s)

Signed for and on behalf of
SGS-CSTC Standards Technical
Services Co., Ltd. GZ Branch Testing
Center

Owen Chen
Operation manager



This document is issued by the Company subject to its General Conditions of Service printed overleaf, available on request or accessible at <http://www.sgs.com/en/terms-and-conditions.aspx> and, for electronic format documents, subject to Terms and Conditions for Electronic Documents at <http://www.sgs.com/en/terms-and-conditions/terms-e-document.aspx>. Attention is drawn to the limitations of liability, indemnification and jurisdiction issues defined therein. Any holder of this document is advised that information contained hereon reflects the Company's findings at the time of its intervention only and within the limits of Client's instructions, if any. The Company's sole responsibility is to its Client and this document does not exonerate parties to a transaction from exercising all their rights and obligations under the transaction documents. This document cannot be reproduced except in full, without prior written approval of the Company. Any unauthorized alteration, forgery or falsification of the content or appearance of this document is unlawful and offenders may be prosecuted to the fullest extent of the law. Unless otherwise stated the results shown in this test report refer only to the sample(s) tested and such sample(s) are retained for 30 days only.

Attention: To check the authenticity of testing inspection report & certificate, please contact us at telephone: (86-755) 83871443, or email: CN.Doccheck@sgs.com

SGS-CSTC Standards Technical Services Co., Ltd.
Guangzhou Branch Testing Center

100 Wafu Road, Saitied Park, Guangzhou Economic Technology Development Zone, Guangzhou, China 510663 | (86-20) 82155555 | (86-20) 82075198 | www.sgs.com
中国·广州·经济技术开发区科学城科珠路190号 邮编: 510663 | (86-20) 82155555 | (86-20) 82075198 | sgs.china@sgs.com

TEST REPORT

No. : GZAT1512011800NM

Date : Dec 21, 2015

Page: 2 of 7

Report Declaration:

The test samples were provided and confirmed by the customer in this report, the results contained in this test report do not relate to other samples of the same product. The manufacturer should ensure that all products manufactured are in conformity with the product sample in this report.

Manufacture Declaration or Comment:

None

Summary of Result(s):

No.	Test Item	Test Method	Conclusion
1.	Flammability	FMVSS 392-1998	Pass
2.	Anti-freezing Test	Provided by client	Pass

Note:
Pass: Meet the requirements
Fail: Does not meet the requirements
NA: Not apply to the judgment



This document is issued by the Company subject to its General Conditions of Service printed overleaf, available on request or accessible at <http://www.sgs.com/en/terms-and-conditions.aspx> and, for electronic formal documents, subject to Terms and Conditions for Electronic Documents at <http://www.sgs.com/en/terms-and-conditions/terms-and-conditions.aspx>. Attention is drawn to the limitation of liability, indemnification and jurisdiction issues defined therein. Any holder of this document is advised that information contained herein reflects the Company's findings at the time of its intervention only and within the limits of Client's instructions, if any. The Company's sole responsibility is to its Client and this document does not exonerate parties to a transaction from exercising all their rights and obligations under the transaction documents. This document cannot be reproduced except in full, without prior written approval of the Company. Any unauthorized alteration, forgery or falsification of the content or appearance of this document is unlawful and offenders may be prosecuted to the fullest extent of the law. Unless otherwise stated the results shown in this test report refer only to the sample(s) tested and such sample(s) are retained for 30 days only.

Attention: To check the authenticity of testing/inspection report & certificate, please contact us at telephone: (86-755) 83271442, or email: sgs@china.sgs.com

SGS (China) Technical Service Co., Ltd.
 Guangzhou Laboratory Service

Room 501, Sanyuanli Park, Guangzhou Economic Technology Development Zone, Guangzhou, China 510633 | (86-20) 82155555 | (86-20) 82075198 | www.sgs.com.cn
 中国·广州·经济技术开发区科学城科韵路198号 邮编: 510633 | (86-20) 82155555 | (86-20) 82075198 | sgs.china@sgs.com

TEST REPORT

No. : GZAT1512011853NM

Date : Dec 21, 2015

Page: 3 of 7

Original Sample Photo:



This document is issued by the Company subject to its General Conditions of Service printed overleaf, available on request or accessible at <http://www.sgs.com/en/Terms-and-Conditions.aspx> and, for electronic formal documents, subject to Terms and Conditions for Electronic Documents at <http://www.sgs.com/en/Terms-and-Conditions/Terms-e-Documents.aspx>. Attention is drawn to the limitation of liability, indemnification and jurisdiction issues defined therein. Any holder of this document is advised that information contained herein reflects the Company's findings at the time of its intervention only and within the limits of Client's instructions, if any. The Company's sole responsibility is to its Client and this document does not exonerate parties to a transaction from exercising all their rights and obligations under the transaction documents. This document cannot be reproduced except in full, without prior written approval of the Company. Any unauthorized alteration, forgery or falsification of the content or appearance of this document is unlawful and offenders may be prosecuted to the fullest extent of the law. Unless otherwise stated the results shown in this test report refer only to the sample(s) tested and such sample(s) are retained for 30 days only.

Attention: To check the authenticity of testing/inspection report & certificate, please contact us at telephone: (86-755) 8377 1443, or email: SM.Saleschina@sgs.com

SGS Spectro Technical Services Co., Ltd.
Guangzhou, China

SGS Spectro Technical Services Co., Ltd.
中国·广州·经济技术开发区科学城科珠路198号 邮编: 510663 | (86-20) 82155555 | (86-20) 82075158 | www.sgs.com.cn
中国·广州·经济技术开发区科学城科珠路198号 邮编: 510663 | (86-20) 82155555 | (86-20) 82075158 | sgs.china@sgs.com

TEST REPORT

No. : GZAT1512011850NM

Date : Dec 21, 2015

Page: 4 of 7

1. Test Item: Flammability

Sample Description: See photo

Test Method: FMVSS 302-1995

Test Condition:

Specimen: 303 mm×100mm×12.4 mm

Conditioning: 21 °C, 65 %RH, 24 h

Test Result:

Specimen	1	2	3	4	5
Burning distance, mm	/	/	/	/	/
Burning time, s	/	/	/	/	/
Burning rate, mm/min	0	0	0	0	0
Maximum burning rate, mm/min	0				

Standard's requirements:

- a) The specimen shall not burn, nor transmit a flame front across its surface, at a rate of more than 102mm per minute, or
- b) The specimen stops burning before it has burned for 60 seconds from the start of timing, and has not burned more than 51mm from the point where timing was started.

Conclusion: Pass

Note:

1. The flame extinguished before the final mark.
2. Test specimens were cut from the sample.
3. The non label surface was the exposed surface.



This document is issued by the Company subject to its General Conditions of Service printed overleaf, available on request or accessible at <http://www.sgs.com/en/Terms-and-Conditions.aspx> and, for electronic format documents, subject to Terms and Conditions for Electronic Documents at <http://www.sgs.com/en/Terms-and-Conditions/Terms-e-Document.aspx>. Attention is drawn to the limitation of liability, indemnification and jurisdiction issues defined therein. Any holder of this document is advised that information contained herein reflects the Company's findings at the time of its intervention only and within the limits of Client's instructions, if any. The Company's sole responsibility is to its Client and this document does not exonerate parties to a transaction from exercising all their rights and obligations under the transaction documents. This document cannot be reproduced except in full, without prior written approval of the Company. Any unauthorized alteration, forgery or falsification of the content or appearance of this document is unlawful and offenders may be prosecuted to the fullest extent of the law. Unless otherwise stated the results shown in this test report refer only to the sample(s) tested and such sample(s) are retained for 30 days only.

Attention: To check the authenticity of testing/inspection report & certificate, please contact us at telephone: (86-755) 8387-1443, or e-mail: SGS.China@sgs.com

SGS (Shenzhen) Testing Service Co., Ltd.
Guangdong Testing Service

19 Nanshan Road, Shenzhen Park, Guanghua Economic Technology Development Zone, Guangzhou, China 510003 | (86-20) 82155555 | (86-20) 82075198 | www.sgs.com
中国·广州·经济技术开发区科学城科苑路198号 邮编: 510003 | (86-20) 82155555 | (86-20) 82075198 | sgs.china@sgs.com

TEST REPORT

No. : GZAT1512011850NM

Date : Dec 21, 2015

Page: 5 of 7

Test Photo:

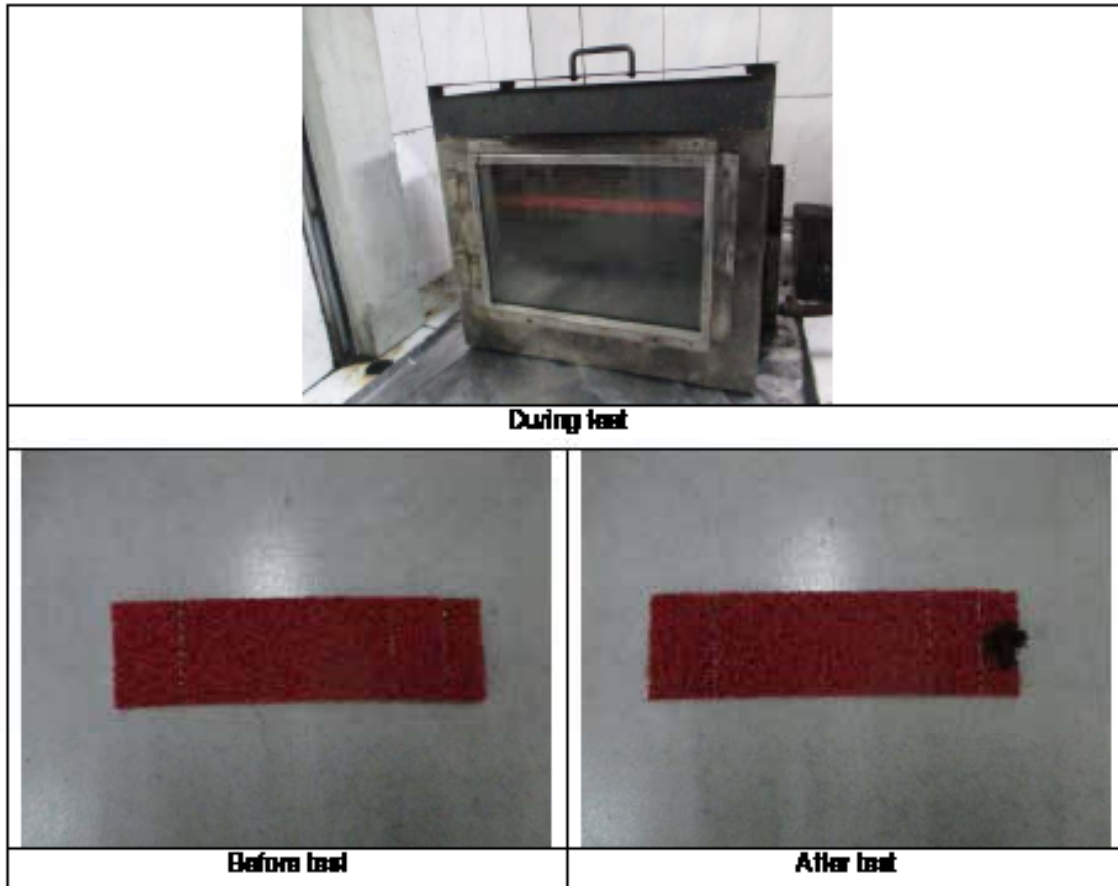

Equipment Information:

Equipment	Model	Equipment No.	Calibration date	Next Calibration date
Horizontal Flame Chamber	HMV	GZMF-PL-E01B	2015-07-13	2016-07-12



This document is issued by the Company subject to its General Conditions of Service printed overleaf, available on request or accessible at <http://www.sgs.com/en/Terms-and-Conditions.aspx> and, for electronic format documents, subject to Terms and Conditions for Electronic Documents at <http://www.sgs.com/en/Terms-and-Conditions/Terms-e-Documents.aspx>. Attention is drawn to the limitation of liability, indemnification and jurisdiction issues defined therein. Any holder of this document is advised that information contained herein reflects the Company's findings at the time of its intervention only and within the limits of Client's instructions, if any. The Company's sole responsibility is to its Client and this document does not constitute part of a transaction from oversteering all their rights and obligations under the transaction documents. This document cannot be reproduced (in full, without prior written approval of the Company. Any unauthorized alteration, forgery or falsification of the content or appearance of this document is unlawful and offenders may be prosecuted to the fullest extent of the law. Unless otherwise stated the results shown in this test report refer only to the sample(s) tested and such sample(s) are retained for 30 days only.

Attention: To check the authenticity of testing inspection report & certificate, please contact us at telephone: (86-755) 8327 1442, or email: CS_09007816@sgs.com

SGS (China) Testing Service Co., Ltd.
Guangzhou Testing Service

199 Foshan Road, Science Park, Guangzhou Economic Technology Development Zone, Guangzhou, China 510003 | (86-20) 82155555 | (86-20) 82075198 | www.sgs.com.cn
中国·广州·经济技术开发区科学城科珠路199号 邮编: 510003 | (86-20) 82155555 | (86-20) 82075198 | sgs.china@sgs.com

TEST REPORT

No. : GZAT1512011800NM

Date : Dec 21, 2015

Page: 8 of 7

2. Test Item: Antifreezing Test

Sample Description: See photo

Test Method: Provided by client

Test Condition:

Condition: -20 °C, 2 h

Number of specimens tested: 1

Lab Environment Condition: 23±2 °C, 55±5 %RH

Test Result:

Test Item	Appearance	Client's requirement	Conclusion
Antifreezing Test	Nonbrittle	Nonbrittle	Pass

Note: Test specimens were cut from the sample.

Test Photo:



This document is issued by the Company subject to its General Conditions of Service printed overleaf, available on request or accessible at <http://www.sgs.com/en/Terms-and-Conditions.aspx> and, for electronic format documents, subject to Terms and Conditions for Electronic Documents at <http://www.sgs.com/en/Terms-and-Conditions/Terms-e-Documents.aspx>. Attention is drawn to the limitation of liability, indemnification and jurisdiction issues defined therein. Any holder of this document is advised that information contained hereon reflects the Company's findings of the time of its intervention only and within the limits of Client's instructions, if any. The Company's sole responsibility is to its Client and this document does not exonerate parties to a transaction from exercising all their rights and obligations under the transaction documents. This document cannot be reproduced except in full, without prior written approval of the Company. Any unauthorized alteration, forgery or falsification of the content or appearance of this document is unlawful and offenders may be prosecuted to the fullest extent of the law. Unless otherwise stated the results shown in this test report refer only to the sample(s) tested and such sample(s) are retained for 30 days only.

Attention: To check the authenticity of testing/inspection report & certificate, please contact us at telephone: (86-755) 8307-1442, or email: cn_ba@cn.tech@sgs.com

SGS (China) Systems Technical Service Co., Ltd.
Guangzhou Branch Office - Testing Service

19F Post Road, Saitan Park, Guangzhou Economic Technology Development Zone, Guangzhou, China 510003 | (86-20) 82155555 | (86-20) 82075198 | www.sgs.com
中国·广州·经济技术开发区科学城科珠路198号 邮编: 510003 | (86-20) 82155555 | (86-20) 82075198 | sgs.china@sgs.com

TEST REPORT

No. : GZAT1512011859NM

Date : Dec 21, 2015

Page: 7 of 7

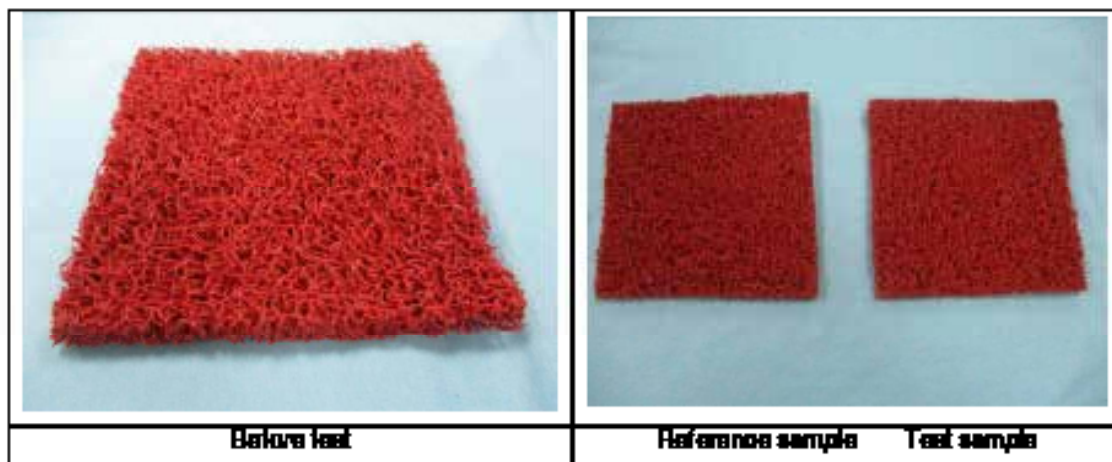

Equipment Information:

Equipment	Model	Equipment No.	Calibration date	Next Calibration date
High/Low Temperature Impact Chamber	MS-WSJ SGS	GZMF-PL-E137	2015-06-24	2016-06-23

***** End of report*****



This document is issued by the Company subject to its General Conditions of Service printed overleaf, available on request or accessible at <http://www.sgs.com/en/Terms-and-Conditions.aspx> and, for electronic format documents, subject to Terms and Conditions for Electronic Documents at <http://www.sgs.com/en/Terms-and-Conditions/Terms-e-Documents.aspx>. Attention is drawn to the limitation of liability, indemnification and jurisdiction issues defined therein. Any holder of this document is advised that information contained herein reflects the Company's findings at the time of its intervention only and within the limits of Client's instructions. If any, The Company's sole responsibility is to its Client and this document does not constitute parties to a transaction from oversteering all their rights and obligations under the transaction documents. This document cannot be reproduced except in full, without prior written approval of the Company. Any unauthorized alteration, forgery or falsification of the content or appearance of this document is unlawful and offenders may be prosecuted to the fullest extent of the law. Unless otherwise stated the results shown in this test report refer only to the sample(s) tested and such sample(s) are retained for 30 days only.

Attention: To check the authenticity of testing inspection report & certificate, please contact us at telephone: (86-755) 8337-1442, or email: CN.Shenzhen@sgs.com

SGS (Shenzhen) Testing Service Co., Ltd. | 深圳瑞尔丹德普尔检测技术有限公司 | 510003 | (86-20) 82155555 | (86-20) 82075198 | www.sgs.com.cn
 中国·广州·经济技术开发区科学城科珠路198号 | 邮编: 510003 | (86-20) 82155555 | (86-20) 82075198 | sgs.china@sgs.com



***Wet Coefficient of Friction
Lab Test Report***

**Prepared For:
Chandler Balch
Director, Technical Services
Skudo, LLC**

**Prepared By:
Brent Johnson
Traction Auditing, LLC
2075 Greenbriar
Southlake, TX 76092
817-230-4004**



Technical Report

TRACTION ADDITING REPORT NUMBER: 5504102018

CUSTOMER NAME: Chandler Balch
Director, Technical Services

TEST DATE: 04/10/2018

SUBJECT MATERIAL: Skudo board

TEST PROCEDURE: ANSI/NFSI B101.3-2012 Wet Dynamic Coefficient of Friction
ANSI/NFSI B101.1-2009 Wet Static Coefficient of Friction

TEST DEVICE: GS-1 Serial # 14A021 Calibrated 04/10/2018

TEST RESULTS:

Wet SCOF

Date	Time	Client	Case	Location	Condition	Test Pad	Oper	SCoF	AVG
10-Apr-18	12:46:14 PM	Skudo	lab 04102018	dome 1	Distilled Water	Neolite	BAJ	0.8615	
10-Apr-18	12:46:49 PM	Skudo	lab 04102018	dome 1	Distilled Water	Neolite	BAJ	0.8856	
10-Apr-18	12:47:39 PM	Skudo	lab 04102018	dome 1	Distilled Water	Neolite	BAJ	0.8036	0.85
10-Apr-18	1:19:35 PM	Skudo	lab 04102018	dome 2	Distilled Water	Neolite	BAJ	0.8125	
10-Apr-18	1:20:07 PM	Skudo	lab 04102018	dome 2	Distilled Water	Neolite	BAJ	0.814	
10-Apr-18	1:20:44 PM	Skudo	lab 04102018	dome 2	Distilled Water	Neolite	BAJ	0.7616	
10-Apr-18	1:21:13 PM	Skudo	lab 04102018	dome 2	Distilled Water	Neolite	BAJ	0.794	0.8
10-Apr-18	1:22:32 PM	Skudo	lab 04102018	dome 3	Distilled Water	Neolite	BAJ	0.7674	
10-Apr-18	1:23:05 PM	Skudo	lab 04102018	dome 3	Distilled Water	Neolite	BAJ	0.7766	
10-Apr-18	1:23:46 PM	Skudo	lab 04102018	dome 3	Distilled Water	Neolite	BAJ	0.7604	
10-Apr-18	1:24:16 PM	Skudo	lab 04102018	dome 3	Distilled Water	Neolite	BAJ	0.7792	0.77
10-Apr-18	1:29:10 PM	Skudo	lab 04102018	dimple 1	Distilled Water	Neolite	BAJ	0.6331	
10-Apr-18	1:29:45 PM	Skudo	lab 04102018	dimple 1	Distilled Water	Neolite	BAJ	0.6248	
10-Apr-18	1:30:13 PM	Skudo	lab 04102018	dimple 1	Distilled Water	Neolite	BAJ	0.65	
10-Apr-18	1:30:44 PM	Skudo	lab 04102018	dimple 1	Distilled Water	Neolite	BAJ	0.6922	0.65
10-Apr-18	1:36:19 PM	Skudo	lab 04102018	dimple 2	Distilled Water	Neolite	BAJ	0.6283	
10-Apr-18	1:36:37 PM	Skudo	lab 04102018	dimple 2	Distilled Water	Neolite	BAJ	0.642	
10-Apr-18	1:37:08 PM	Skudo	lab 04102018	dimple 2	Distilled Water	Neolite	BAJ	0.6536	
10-Apr-18	1:37:30 PM	Skudo	lab 04102018	dimple 2	Distilled Water	Neolite	BAJ	0.669	0.65
10-Apr-18	1:42:49 PM	Skudo	lab 04102018	dimple 3	Distilled Water	Neolite	BAJ	0.6766	
10-Apr-18	1:43:13 PM	Skudo	lab 04102018	dimple 3	Distilled Water	Neolite	BAJ	0.6659	
10-Apr-18	1:43:35 PM	Skudo	lab 04102018	dimple 3	Distilled Water	Neolite	BAJ	0.7069	
10-Apr-18	1:43:58 PM	Skudo	lab 04102018	dimple 3	Distilled Water	Neolite	BAJ	0.686	0.68

Technical Report

Wet DCOF

Date	Time	Client	Case	Location	Condition	Test Pad	Oper	DCoF	AVG
10-Apr-18	12:49:10 PM	Skudo	lab 04102018	dome 1	SLS	SBR	BAJ	0.547	
10-Apr-18	12:49:52 PM	Skudo	lab 04102018	dome 1	SLS	SBR	BAJ	0.4801	
10-Apr-18	12:50:28 PM	Skudo	lab 04102018	dome 1	SLS	SBR	BAJ	0.4039	
10-Apr-18	12:51:08 PM	Skudo	lab 04102018	dome 1	SLS	SBR	BAJ	0.444	0.47
10-Apr-18	12:54:47 PM	Skudo	lab 04102018	dome 2	SLS	SBR	BAJ	0.4914	
10-Apr-18	12:55:21 PM	Skudo	lab 04102018	dome 2	SLS	SBR	BAJ	0.4069	
10-Apr-18	12:55:51 PM	Skudo	lab 04102018	dome 2	SLS	SBR	BAJ	0.3956	
10-Apr-18	12:56:27 PM	Skudo	lab 04102018	dome 2	SLS	SBR	BAJ	0.3878	0.42
10-Apr-18	1:25:31 PM	Skudo	lab 04102018	dome 3	SLS	SBR	BAJ	0.4885	
10-Apr-18	1:26:07 PM	Skudo	lab 04102018	dome 3	SLS	SBR	BAJ	0.459	
10-Apr-18	1:26:37 PM	Skudo	lab 04102018	dome 3	SLS	SBR	BAJ	0.4235	
10-Apr-18	1:27:08 PM	Skudo	lab 04102018	dome 3	SLS	SBR	BAJ	0.4689	0.46
10-Apr-18	1:32:29 PM	Skudo	lab 04102018	dimple 1	SLS	SBR	BAJ	0.4639	
10-Apr-18	1:33:02 PM	Skudo	lab 04102018	dimple 1	SLS	SBR	BAJ	0.3886	
10-Apr-18	1:33:30 PM	Skudo	lab 04102018	dimple 1	SLS	SBR	BAJ	0.3861	
10-Apr-18	1:34:01 PM	Skudo	lab 04102018	dimple 1	SLS	SBR	BAJ	0.4074	0.41
10-Apr-18	1:38:48 PM	Skudo	lab 04102018	dimple 2	SLS	SBR	BAJ	0.4155	
10-Apr-18	1:39:12 PM	Skudo	lab 04102018	dimple 2	SLS	SBR	BAJ	0.3893	
10-Apr-18	1:39:34 PM	Skudo	lab 04102018	dimple 2	SLS	SBR	BAJ	0.3947	
10-Apr-18	1:39:55 PM	Skudo	lab 04102018	dimple 2	SLS	SBR	BAJ	0.3397	0.38
10-Apr-18	1:44:52 PM	Skudo	lab 04102018	dimple 3	SLS	SBR	BAJ	0.4306	
10-Apr-18	1:45:15 PM	Skudo	lab 04102018	dimple 3	SLS	SBR	BAJ	0.427	
10-Apr-18	1:45:37 PM	Skudo	lab 04102018	dimple 3	SLS	SBR	BAJ	0.4158	
10-Apr-18	1:46:00 PM	Skudo	lab 04102018	dimple 3	SLS	SBR	BAJ	0.413	0.42

DATA INTERPRETATION

For Wet Static Coefficient of Friction results interpreted per the ranges set forth in the ANSI/NFPA B101.1-2009 Test Method for Measuring Wet Static Coefficient of Friction of Common Hard Surface Floor Materials

For Wet Dynamic Coefficient of Friction results interpreted per the ranges set forth in the: ANSI/NFPA B101.3-2012 Test Method for Measuring Wet Dynamic Coefficient of Friction of Common Hard Surface Floor Materials

Table 1-ANSI/NFPA B101.1-2009

Wet SCOF Value (μ)	Available Traction	Remediation
$m\mu \geq 0.60$	High Traction - Lower probability of slipping	Monitor SCOF regularly and maintain cleanliness.
$0.40 \leq m\mu < 0.60$	Moderate Traction - Increased probability of slipping	Monitor SCOF regularly and maintain cleanliness. Consider traction enhancing products and technologies.
$m\mu < 0.40$	Minimal Available Traction - Higher probability of slipping	Seek professional intervention. Consider replacing flooring and/or coating with high traction products.

NOTE: It is important to note that these categories are not indicative of all possible conditions. There are numerous variables that may add to, or take from the available traction of any given floor surface. (i.e. type or style of footwear, types and frequency contaminants, pedestrian preoccupation, etc.) These ranges were established based on a list of approved tribometers, which were in turn based on a specific set of selection criteria. As such, these values contained in Table 1, have not been validated against the full range of other tribometers. Data produced by tribometers which are not designed to measure wet SCOF do not necessarily correlate to the values listed in Table 1.

Table 1- ANSI/NFPA B101.3-2012

Wet DCOF Value (μ)	Slip Resistance Potential	Action
>0.45 (inclines) $m\mu > 0.42$	High - Lower probability of slipping	Monitor SCOF regularly and maintain cleanliness.
$0.30 \leq m\mu < 0.45$ (inclines) $0.30 \leq m\mu < 0.42$	Acceptable - Increased probability of slipping	Monitor SCOF regularly and maintain cleanliness. Consider traction enhancing products and technologies.
$m\mu < 0.30$	Low - Higher probability of slipping	Seek professional intervention. Consider replacing flooring and/or coating with high traction products.

NOTE: It is important to note that these categories are not indicative of all possible conditions. There are numerous variables that may add to, or take from the available traction of any given floor surface. (i.e. type or style of footwear, types and frequency contaminants, pedestrian preoccupation, etc.) The DCOF ranges were established based on research done in Europe utilizing empirical and mathematical techniques and were validated in the laboratory and field through extensive testing with the following standardized methods: DIN 15267 – B57 Tester; DIN 51130 – German Ramp; DIN 51131 – GAG 2000 Tester. These values would be applicable to other test methods or devices which can produce an R correlation of greater than 0.80 to one of these three reference standards. Data produced by tribometers which are not designed to measure wet DCOF do not necessarily correlate to the values listed in Table 1. Results of dry and wet tests should be view independent of each other, and not compared.

Test completed and testified to by:

Brent A. Johnson
ANSI/WACH 0001
04/10/2018



***Wet Coefficient of Friction
Lab Test Report***

**Prepared For:
Chandler Balch
Director, Technical Services
Skudo, LLC**

**Prepared By:
Brent Johnson
Traction Auditing, LLC
2075 Greenbriar
Southlake, TX 76092
817-230-4004**



Technical Report

TRACTION AUDITING REPORT NUMBER: SS02012019

CUSTOMER NAME: Chandler Balch
Director, Technical Services

TEST DATE: 02/01/2019

SUBJECT MATERIAL: Skudo board **TEST DEVICE:** GS-1 Serial # 14A021 Calibrated 02/01/2019

TEST PROCEDURE: ANSI/NFSI B101.3-2012 Wet Dynamic Coefficient of Friction
ANSI/NFSI B101.1-2009 Wet Static Coefficient of Friction

TEST RESULTS:

Wet SCOF

Date	Time	Client	Case	Location	Condition	Test Pad	Oper	SCoF	AVG
1-Feb-19	2:16:30 PM	Skudo	Gray	TA 1	Distilled Water	Neolite	BAJ	0.62	
1-Feb-19	2:17:13 PM	Skudo	Gray	TA 1	Distilled Water	Neolite	BAJ	0.64	
1-Feb-19	2:17:43 PM	Skudo	Gray	TA 1	Distilled Water	Neolite	BAJ	0.65	
1-Feb-19	2:18:25 PM	Skudo	Gray	TA 1	Distilled Water	Neolite	BAJ	0.71	
1-Feb-19	2:28:02 PM	Skudo	Gray	TA 2	Distilled Water	Neolite	BAJ	0.65	
1-Feb-19	2:28:36 PM	Skudo	Gray	TA 2	Distilled Water	Neolite	BAJ	0.7	
1-Feb-19	2:29:03 PM	Skudo	Gray	TA 2	Distilled Water	Neolite	BAJ	0.69	
1-Feb-19	2:29:35 PM	Skudo	Gray	TA 2	Distilled Water	Neolite	BAJ	0.65	
1-Feb-19	2:34:09 PM	Skudo	Gray	TA 3	Distilled Water	Neolite	BAJ	0.68	
1-Feb-19	2:34:44 PM	Skudo	Gray	TA 3	Distilled Water	Neolite	BAJ	0.73	
1-Feb-19	2:35:15 PM	Skudo	Gray	TA 3	Distilled Water	Neolite	BAJ	0.71	
1-Feb-19	2:35:45 PM	Skudo	Gray	TA 3	Distilled Water	Neolite	BAJ	0.77	

Wet DCOF

Date	Time	Client	Case	Location	Condition	Test Pad	Oper	DCoF	AVG
1-Feb-19	2:24:27 PM	Skudo	Gray	TA 1	SLS	SBR	BAJ	0.33	
1-Feb-19	2:24:59 PM	Skudo	Gray	TA 1	SLS	SBR	BAJ	0.34	
1-Feb-19	2:25:26 PM	Skudo	Gray	TA 1	SLS	SBR	BAJ	0.32	
1-Feb-19	2:25:54 PM	Skudo	Gray	TA 1	SLS	SBR	BAJ	0.34	
1-Feb-19	2:31:07 PM	Skudo	Gray	TA 2	SLS	SBR	BAJ	0.39	
1-Feb-19	2:31:33 PM	Skudo	Gray	TA 2	SLS	SBR	BAJ	0.39	
1-Feb-19	2:31:56 PM	Skudo	Gray	TA 2	SLS	SBR	BAJ	0.36	
1-Feb-19	2:32:21 PM	Skudo	Gray	TA 2	SLS	SBR	BAJ	0.4	
1-Feb-19	2:37:24 PM	Skudo	Gray	TA 3	SLS	SBR	BAJ	0.39	
1-Feb-19	2:37:54 PM	Skudo	Gray	TA 3	SLS	SBR	BAJ	0.35	
1-Feb-19	2:38:21 PM	Skudo	Gray	TA 3	SLS	SBR	BAJ	0.35	
1-Feb-19	2:38:49 PM	Skudo	Gray	TA 3	SLS	SBR	BAJ	0.36	



Technical Report

DATA INTERPRETATION

For Wet Static Coefficient of Friction results interpreted per the ranges set forth in the ANSI/NFSI B101.1-2009 Test Method for Measuring Wet Static Coefficient of Friction of Common Hard Surface Floor Materials

For Wet Dynamic Coefficient of Friction results interpreted per the ranges set forth in the: ANSI/NFSI B101.3-2012 Test Method for Measuring Wet Dynamic Coefficient of Friction of Common Hard Surface Floor Materials

Table 1-ANSI/NFSI B101.1-2009

Wet SCOF Value (μ)	Available Traction	Remediation
$m\mu \geq 0.60$	High Traction - Lower probability of slipping	Monitor SCOF regularly and maintain cleanliness.
$0.40 \leq m\mu < 0.60$	Moderate Traction - Increased probability of slipping	Monitor SCOF regularly and maintain cleanliness. Consider traction enhancing products and technologies.
$m\mu < 0.40$	Minimal Available Traction - Higher probability of slipping	Seek professional intervention. Consider replacing flooring and/or coating with high traction products.

NOTE: It is important to note that these categories are not indicative of all possible conditions. There are numerous variables that may add to, or take from the available traction of any given floor surface. (ie: type or style of footwear, types and frequency contaminants, pedestrian preoccupation, etc). These ranges were established based on a list of approved tribometers, which were in turn based on a specific set of selection criteria. As such, these values contained in Table 1. have not been validated against the full range of other tribometers. Data produced by tribometers which are not designed to measure wet SCOF do not necessarily correlate to the values listed in Table 1.

Table 1- ANSI/NFSI B101.3-2012

Wet DCOF Value (μ)	Slip Resistance Potential	Action
>0.45 (inclines) $m\mu > 0.42$	High - Lower probability of slipping	Monitor DCOF regularly and maintain cleanliness.
0.30 ≤ mu < 0.45 (inclines) $0.30 \leq m\mu < 0.42$	Acceptable - Increased probability of slipping	Monitor DCOF regularly and maintain cleanliness. Consider traction enhancing products and technologies.
$m\mu < 0.30$	Low - Higher probability of slipping	Seek professional intervention. Consider replacing flooring and/or coating with high traction products.

**NOTE: It is important to note that these categories are not indicative of all possible conditions. There are numerous variables that may add to, or take from the available traction of any given floor surface. (ie: type or style of footwear, types and frequency contaminants, pedestrian preoccupation, etc.) The DCOF ranges were established based on research done in Europe utilizing empirical and mathematical techniques and were validated in the laboratory and field through extensive testing with the following standardized methods: DIN 13287 – BST Tester; DIN 51130 – German Ramp; DIN 51131 – GMG 2000 Tester. These values would be applicable to other test methods or devices which can produce an R correlation of greater than 0.80 to one of these three reference standards. Data produced by tribometers which are not designed to measure wet DCOF do not necessarily correlate to the values listed in Table 1. Results of dry and wet tests should be view independent of each other, and not compared.*

Test completed and testified to by:
Brent A. Johnson
 ANSI/WACH 0001
 02/01/2019

TEST REPORT

No. : GZIN1809050100SC

Date : Sep 30, 2018

Page: 1 of 4

CUSTOMER NAME: SKUDO MANUFACTURING PTY LTD.
 ADDRESS: 47 VERONICA DRIVE TALLAI QLD AUSTRALIA

Sample Name : SKUDO HT BOARD

Above information and sample(s) was/were submitted and confirmed by the client. SGS, however, assumes no responsibility to verify the accuracy, adequacy and completeness of the sample information provided by client.

SGS Ref. No. : SDHL1809021618FB
 Date of Receipt : Sep 19, 2018
 Testing Start Date : Sep 19, 2018
 Testing End Date : Sep 28, 2018
 Test result(s) : For further details, please refer to the following page(s)
 (Unless otherwise stated the results shown in this test report refer only to the sample(s) tested)

Signed for
 SGS-CSTC Standards Technical
 Services Co., Ltd. GZ Branch Testing
 Center

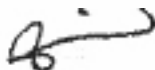

Eleain Fan
 Authorized signatory

Test Result Summary



Unless otherwise agreed in writing, this document is issued by the Company subject to its General Conditions of Service printed overleaf, available on request or accessible at <http://www.sgs.com/terms-and-conditions.aspx> and, for electronic format documents, subject to Terms and Conditions for Electronic Documents at <http://www.sgs.com/terms-and-conditions/171946-0000001.aspx>. Attention is drawn to the limitation of liability, indemnification and jurisdiction issues set forth therein. Any holder of this document is advised that information contained herein reflects the Company's findings at the time of its intervention only and within the limits of Client's instructions, if any. The Company's sole responsibility is to its Client and this document does not constitute advice to a transaction from scanning all their rights and obligations under the transaction documents. This document cannot be reproduced except in full, without prior written approval of the Company. Any unauthorized alteration, forgery or falsification of the content or appearance of this document is unlawful and offenders may be prosecuted to the fullest extent of the law. Unless otherwise stated the results shown in this test report refer only to the sample(s) named and each sample(s) are retained for 30 days only.

Attention: To check the authenticity of testing inspection report & certificate, please contact us at telephone: (86-755) 8332 5443, or email: CN_Doccheck@sgs.com

中国·广州·越秀技术开发区先烈中路104号 邮编: 510005 | (86-20) 82102881 | (86-20) 82070585 | www.sgs.com.cn
 中国·广州·越秀技术开发区先烈中路104号 邮编: 510005 | (86-20) 82102881 | (86-20) 82070585 | sgs.china@sgs.com

TEST REPORT

No. : GZIN1809050100SC

Date : Sep 30, 2018

Page: 2 of 4

Test(s) Requested	Result(s)
16 CFR 1630-Standard for the surface flammability of carpets and rugs (FF 1-70)	PASS

Summary:

- For further details, please refer to the following page(s).



Unless otherwise agreed in writing, this document is issued by the Company subject to its General Conditions of Service printed overleaf, available on request or accessible at <http://www.sgs.com/sgsweb/conditions-general-service.html> and, for clients based in America, subject to Terms and Conditions for Electronic Transactions at <http://www.sgs.com/sgsweb/terms-and-conditions/terms-and-conditions.html>. Attention is drawn to the limitation of liability, non-warranty and jurisdiction clause set forth therein. Any holder of this document is advised that information contained herein reflects the Company's findings of the time of its intervention only and within the limits of Client's instructions, if any. The Company's sole responsibility is to its Client and this document does not constitute parties to a transaction that availing of their rights and obligations under the transaction documents. This document cannot be reproduced except in full, without prior written approval of the Company. Any unauthorized alteration, forgery or falsification of the content or appearance of this document is unlawful and offenders may be prosecuted to the fullest extent of the law. Unless otherwise stated the results shown in this test report refer only to the sample(s) named and such sample(s) are retained for 30 days only.

Attention: To check the authenticity of testing certificates, please contact us at telephone +86-21-51085107 1443, or email CN.Docs@sgs.com

SGS (China) Co., Ltd. | 中国·广州·经济技术开发区科学城萝岗路100号 | 邮编: 510663 | 电话: +86-20-82759280 | 传真: +86-20-82759280 | 网站: www.sgs.com.cn

TEST REPORT

No. : GZIN1809050100SC

Date : Sep 30, 2018

Page: 3 of 4

TESTS AND RESULTS

Test Conducted:

16 CFR 1630-Standard for the surface flammability of carpets and rugs (FF 1-70).

Conditioning:

1. Laundering condition: No, as per client's requirement.
2. Oven conditioning: T: 105°C Duration: 2 hours, then cool for 1hour in desiccator.

Requirement:

1. A specimen passes the test if the charred portion does not extend to within 2.54 cm. (1.0 in.) of the edge of the hole in the flattening frame at any point;
2. At least seven of the eight specimens shall meet the test criterion in order to conform with this Standard.

Test Details:

Specimen No.	The charred portion extend to within 2.54 cm. (1.0 in.) of the edge of the hole in the flattening frame at any point.(Yes or No)	Rating
1	No	Pass
2	No	Pass
3	No	Pass
4	No	Pass
5	No	Pass
6	No	Pass
7	No	Pass
8	No	Pass

Conclusion:

As per test method of the 16CFR 1630 contained, the submitted specimens comply with the requirement.



Unless otherwise agreed in writing, this document is issued by the Company subject to its General Conditions of Service printed on the reverse side of this document and available at www.sgs.com and, for electronic format documents, subject to terms and conditions for electronic documents in www.sgs.com. Attention is drawn to the limitation of liability, indemnification and jurisdiction clause set forth therein. Any holder of this document is advised that information contained herein reflects the Company's findings at the time of its intervention only and within the limits of Client's instructions, if any. The Company's sole responsibility is to its Client and this document does not constitute advice to a transaction from exercising all their rights and obligations under the transaction documents. This document cannot be reproduced except in full, without prior written approval of the Company. Any unauthorized alteration, forgery or falsification of the content or appearance of this document is unlawful and offenders may be prosecuted to the fullest extent of the law. Unless otherwise stated the rights shown in this test report refer only to the sample(s) tested and each sample(s) are retained for 30 days only.

Attention: To check the authenticity of testing instructions report & certificates, please contact us at telephone +86-755-83071443 or email: CN.Desktop@sgs.com
 中国·广州·越秀技术开发区科学城兴科路198号 邮编: 510663 1 (86-02) 82122881 / (86-02) 82270300 www.sgs.com.cn
 中国·广州·越秀技术开发区科学城兴科路198号 邮编: 510663 1 (86-02) 82122881 / (86-02) 82270300 4 sgs.china@sgs.com

TEST REPORT

No. : GZIN1809050100SC

Date : Sep 30, 2018

Page: 4 of 4

SAMPLE INFORMATION AND PICTURES

Sample No.	Description
S 1	SKUDO HT BOARD

Sample as Received

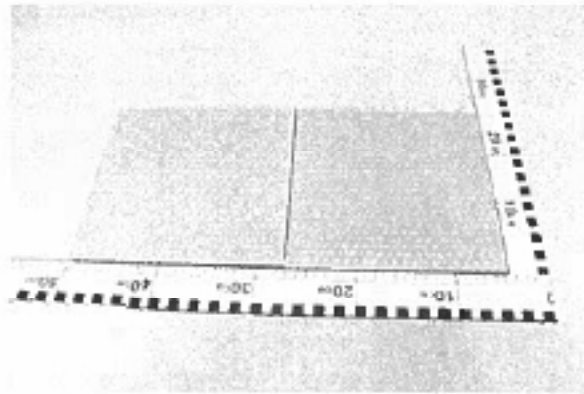

Appendix Information:

The above test was carried out by SGS-CSTC Standards Technical Services Co., Ltd. Shunde Branch

***** End of report*****



Unless otherwise agreed in writing, this document is issued by the Company subject to its General Conditions of Service printed overleaf, available on request or accessible at www.sgs.com (Terms and Conditions apply) and, for standardized documents, subject to Terms and Conditions for Electronic Documents at www.sgs.com (Terms and Conditions apply). Attention is drawn to the limitation of liability, non-warranty and limitation (where defined therein). Any holder of this document is advised that information contained herein reflects the Company's findings at the time of its intervention only and within the limits of Client's instructions, if any. The Company's sole responsibility is to its Client and this document does not constitute parties to a transaction from scrambling all their data and obligations under the transaction documents. This document cannot be reproduced except in full, without prior written approval of the Company. Any unauthorized alteration, forgery or falsification of the content or appearance of this document is strictly prohibited and offenders may be prosecuted to the fullest extent of the law. Unless otherwise stated the results shown in this test report refer only to the sample(s) tested and such sample(s) are retained for 30 days only. Director to check the authenticity of testing documents report & certificate, please contact us at china@sgs.com or www.sgs.com

SGS-CSTC Standards Technical Services Co., Ltd. (Shunde Branch) | 100000 | 1 (86-20) 82102881 | 1 (86-20) 82070000 | www.sgs.com
 中国·广东·顺德技术开发区科学城科顺路100号 | 邮编: 510000 | 1 (86-20) 82102881 | 1 (86-20) 82070000 | sgs.china@sgs.com

TEST REPORT

No. : GZIN1809050095SC

Date : Sep 30, 2018

Page: 1 of 5

CUSTOMER NAME: SKUDO MANUFACTURING PTY LTD.
ADDRESS: 47 VERONICA DRIVE TALLAI QLD AUSTRALIA

Sample Name : SKUDO HT BOARD

Above information and sample(s) was/were submitted and confirmed by the client. SGS, however, assumes no responsibility to verify the accuracy, adequacy and completeness of the sample information provided by client.

SGS Ref. No. : SDHL1809021616FB
Date of Receipt : Sep 19, 2018
Testing Start Date : Sep 19, 2018
Testing End Date : Sep 28, 2018
Test result(s) : For further details, please refer to the following page(s)
(Unless otherwise stated the results shown in this test report refer only to the sample(s) tested)

Signed for
SGS-CSTC Standards Technical
Services Co., Ltd. GZ Branch Testing
Center

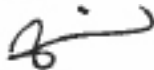

Eleain Fan
Authorized signatory



Unless otherwise agreed in writing, this document is issued by the Company subject to its General Conditions of Service printed on the reverse side of this document or accessible at www.sgs.com (hereinafter referred to as "Conditions of Service"). This document, subject to these and Conditions for Electronic Documents at www.sgs.com (hereinafter referred to as "Conditions for Electronic Documents"), is subject to the limitation of liability, indemnification and arbitration clause set forth therein. Any holder of this document is advised that information contained herein is the Company's property and is to be used only for the purpose of the Client's involvement, if any. The Company's sole responsibility is to its Client and this document does not constitute parties to a transaction from assuming all their rights and obligations under the transaction documents. This document cannot be reproduced except in full, without prior written approval of the Company. Any unauthorized alteration, forgery or falsification of the content or appearance of this document is unlawful and offenders may be prosecuted to the fullest extent of the law. Unless otherwise stated the results shown in this test report refer only to the sample(s) tested and such sample(s) are retained for 90 days only.

Attention: To check the authenticity of testing/inspection report & certificates, please contact us at shuofan@sgs.com / 8187 5443, or email: CN.Douche@sgs.com

Website: www.sgs.com / www.cn.sgs.com / www.sgsgroup.com.cn

中国 - 广州 - 越秀技术开发区兴学路100号 邮编: 510665 | 电话: 81875443 | 86-20-82070000 | sgs@sgs.com

TEST REPORT

No. : GZIN1809050095SC

Date : Sep 30, 2018

Page: 2 of 5

Test Result Summary

No.	Test(s) Requested	Result(s)	Comments
1	ASTM E 648-17a	Class I	/
For further details, please refer to the following page(s)			



Unless otherwise agreed in writing, this document is issued to the Company subject to its General Conditions of Service printed overleaf, available on request or accessible at www.sgs.com for Terms and Conditions, along with, for electronic format documents, subject to Terms and Conditions for electronic Documents available at www.sgs.com. A copy of the General Conditions of Service and Terms and Conditions for electronic Documents is drawn to the attention of the Client, Identification and Information issued without charge. Any holder of this document is advised that information contained herein reflects the Company's findings at the time of its intervention only and within the limits of Client's intervention, if any. The Company's sole responsibility is to its Client and this document does not constitute parties to a transaction from assuming of their rights and obligations under the transaction documents. This document cannot be reproduced, stored in a retrieval system, or transmitted, in any form or by any means, electronic, mechanical, photocopying, recording, or by any information storage and retrieval system, without prior written approval of the Company. Any unauthorized alteration, forgery or falsification of the content or appearance of this document is unlawful and offenders may be prosecuted to the fullest extent of the law. Unless otherwise stated the results shown in this test report refer only to the sample(s) tested and such sample(s) are retained for 90 days only.

Attention: To check the authenticity of testing / inspection report & certificate, please contact us @ china@sgs.com (86-755) 83271442, or email CN.Doccheck@sgs.com

中国·广州·越秀区大新街100号 邮编: 510665 | 86-20-82155861 | 86-20-82279290 www.sgs.com.cn
 中国·广州·越秀区大新街100号 邮编: 510665 | 86-20-82155861 | 86-20-82279290 sgs.china@sgs.com

TEST REPORT

No. : GZIN1809050095SC

Date : Sep 30, 2018

Page: 3 of 5

Test conducted:

ASTM E648-17a Standard test method for critical radiant flux of floor-covering systems using a radiant heat energy source.

I. General information

Precondition	Temperature: (21±3)°C Humidity: (50±5)%, Duration: 168h
Mounting method	The specimens were fixed mechanically to the substrate (The substrate is a 13mm thickness 0.58g/cm ³ inorganic millboard).

II. Test results

Flame front advance			
Distance (cm)	Specimen 1	Specimen 2	Specimen 3
	Time (minute: second)	Time (minute: second)	Time (minute: second)
5	9:37	9:17	9:15
10	14:18	13:51	14:07
15	18:34	17:09	18:17
20	22:29	21:17	23:47
25	27:00	25:49	29:12
30	31:36	29:18	35:47
35	40:41	36:46	42:48
40	-	44:52	49:21
45	-	-	-
50	-	-	-
55	-	-	-
60	-	-	-
65	-	-	-
70	-	-	-
75	-	-	-
80	-	-	-
85	-	-	-



Unless otherwise agreed in writing, this document is issued by the Company subject to its General Conditions of Service printed overleaf, available on request or accessible at <http://www.sgs.com/sgscms/sgs-conditions-of-service> and, for electronic based documents, subject to Terms and Conditions for Electronic Documents at <http://www.sgs.com/sgscms/terms-and-conditions-terms-conditions>. Attention is drawn to the limitation of liability, subordination and jurisdiction stated therein. Any holder of this document is advised that information contained herein reflects the Company's findings at the time of its intervention only and within the limits of Client's instructions, if any. The Company's sole responsibility is to its Client and this document does not constitute advice to a third party. This document is the property of the Company. Any unauthorized alteration, forgery or falsification of the content or appearance of this document is unlawful and offenders may be prosecuted to the fullest extent of the law. Unless otherwise stated the results shown in this test report refer only to the sample(s) named and such sample(s) are retained for 90 days only. Appendix: To check the suitability of testing? Inquiries please contact our Client Focus, please contact us at china@sgs.com 1442, or email: CN.Dashboard@sgs.com

SGS (Shanghai) Inspection & Testing Co., Ltd. (Shanghai) 10005 | (86-21) 62109881 | (86-21) 62109800 | www.sgs.com.cn
 中国·广州·越秀区北京路100号 | 邮编: 510055 | (86-20) 62109881 | (86-20) 62109800 | sgs.china@sgs.com

TEST REPORT

No. : GZIN1809050095SC

Date : Sep 30, 2018

Page: 4 of 5

Distance (cm)	Specimen 1	Specimen 2	Specimen 3
	Time (minute: second)	Time (minute: second)	Time (minute: second)
90	-	-	-
95	-	-	-
100	-	-	-
Extinguishing time	52:14	50:47	54:14
Burned distance (cm)	38	40	41
Observations	Melting	Melting	Melting

Calculation:

	Specimen 1	Specimen 2	Specimen 3	Average	S	V
Critical radiant flux (W/cm ²)	0.56	0.52	0.50	0.53	0.03	5.7

Note: S-estimated standard deviation; V-coefficient of variation

The classifications are as follows:

	Class I	Class II
Critical Radiant Flux, watts/cm ²	≥ 0.45	≥ 0.22

Since the tested sample received a Critical Radiant Flux ≈ 0.53 watts/cm², it would meet the requirement of Class I Interior Floor Finish.

STATEMENTS:

The test results relate to the behaviour of the test specimens of a product under the particular conditions of the test; they are not intended to be the sole criterion for assessing the potential fire hazard of the product in use.

The test results relate only to the specimens of the product in the form in which were tested. Small differences in the composition or thickness of the product may significantly affect the performance during the test and may therefore invalidate the test results. Care should be taken to ensure that any product, which is supplied or used, is fully represented by the specimens, which were tested.



Unless otherwise agreed in writing, this document is issued by the Company subject to its General Conditions of Service printed overleaf, available on request or accessible at <http://www.sgs.com> Terms and Conditions apply, for single and limited transactions, subject to Terms and Conditions for Recurring Transactions at <http://www.sgs.com/terms-and-conditions> for new customers only. Attention is drawn to the limitation of liability, indemnification and jurisdiction clause stated therein. No part of this document is without fault information excepted service, subject to the Company's liability at the time of its information entry and within the limits of the Client's instructions, if any. The Company's sole responsibility is to its Client and this document does not constitute advice in a transaction that absolving all their rights and obligations under the transaction documents. This document cannot be reproduced or used in full, without prior written approval of the Company. Any unauthorized alteration, forgery or falsification of the content or appearance of this document is unlawful and offenders may be prosecuted to the fullest extent of the law. Unless otherwise stated the results shown in this test report refer only to the sample(s) listed and each sample(s) are retained for 90 days only. Attention To check the authenticity of testing / inspection reports & certificate, please contact us at info@sgs.com 8017 8432, or email: CS.Deecheck@sgs.com

SGS (UK) Limited, Registered Office: 100 Brook Street, London, W1A 1AA, UK. Tel: +44 (0)20 7620 6000 | Fax: +44 (0)20 7620 6001 | www.sgs.com
 中國 - 廣州 - 越秀技術開發區東環路100號 電話: 810885 | 傳真: 810886 | 86-20-82700000 | sgs.cn@sgs.com

TEST REPORT

No. : GZIN1809050095SC

Date : Sep 30, 2018

Page: 5 of 5

Photo Appendix:

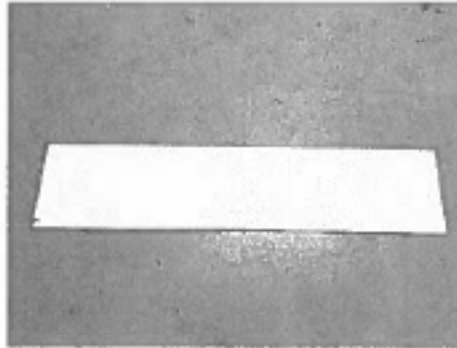

Appendix Information:

The above test was carried out by SGS-CSTC Standards Technical Services Co., Ltd. Shunde Branch

***** End of report*****



Unless otherwise agreed in writing, this document is issued by the Company subject to its General Conditions of Service printed on the reverse, available on request or accessible at <http://www.sgs.com> and its specific Conditions of Service and, for electronic format documents, subject to Terms and Conditions for Electronic Documents at <http://www.sgs.com>. Attention is drawn to the limitation of liability, indemnification and jurisdiction clause therein. Any holder of this document is advised that information contained herein reflects the Company's findings at the time of its intervention only and within the limits of Client's instructions, if any. The Company's sole responsibility is to its Client and this document does not constitute parties to a transaction from accepting all their rights and obligations under the transaction documents. This document cannot be reproduced except in full, without prior written approval of the Company. Any unauthorized alteration, forgery or falsification of the content or appearance of this document is unlawful and offenders may be prosecuted to the fullest extent of the law. Unless otherwise stated the results shown in this test report refer only to the sample(s) tested and each sample(s) are retained for 30 days only.

Attention: To check the authenticity of testing / inspection report & certificate, please contact us at www.sgs.com / 80071663, or email: CN_Online@sgs.com
 中国·广州·越秀技术开发区西华路108号 邮编: 510603 | (86-20) 87155991 | (86-20) 87078090 | www.sgs.com.cn
 中国·广州·越秀技术开发区西华路108号 邮编: 510603 | (86-20) 87155991 | (86-20) 87078090 | sgs.china@sgs.com

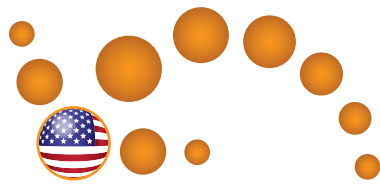

Skudo®

Skudo® is at work for construction firms worldwide



SKANSKA



Balfour Beatty



C.W. Driver
BUILDERS SINCE 1915



HOAR
CONSTRUCTION

Austin Commercial



Gilbane



RYAN

AECOM

LEASE CRUTCHER
Lewis



CROSSLAND
CONSTRUCTION COMPANY, INC.

BRASFIELD
& GORRIE
GENERAL CONTRACTORS

McCOWN
GORDON
CONSTRUCTION



WT
WHITING-TURNER

TRUEBECK
CONSTRUCTION



SWINERTON
BUILDERS



RUDOLPH SLETTEN



BNB
BNBuilders

TELLEPSEN

HITT

CLAYCO

JOERIS
General Contractors

ARCO MURRAY



KAST
construction



Turner

USA • Canada • Mexico • South America

www.skudousa.com

1-888-Skudo11

(1-888-758-3611)